

BUTTERFLY VALVES



ABOUT CNC FLOW CONTROL

CNC Flow Control is headquartered in Houston, Texas with multiple other locations in the U.S. and Canada. Our company unifies several trusted valve and flow line brands that have been serving numerous industries in North America for nearly three decades. From long range projects to same-day delivery, our diverse team is dedicated to understanding customers' needs in order to ensure exceptional service and the best solutions. Our extensive product portfolio ranges from commodity products like hammer unions and needle valves, to highly engineered products like API 6D trunnion mounted ball valves.

Quality assurance is critical to CNC Flow Control's process and we hold multiple internationally recognized quality standards certifications and management system. We are dedicated to understanding our customers' needs to ensure exceptional service by offering an in-house engineering and product management team, an extremely large product portfolio and extensive inventory to support same day shipments.



ABOUT OUR C&C BRAND

C&C's breadth of available products is extremely diverse. From hammer unions to ball valves, C&C products complement most any stocking portfolio. C&C has provided the market with quality valves and fittings for nearly three decades. Today, C&C products are seen in almost all upstream oil and gas applications throughout North America.

CONTENTS

HOW TO ORDER GUIDE	02
C200 SERIES WAFER & LUG	03 - 04
LR/LG200 SERIES WAFER & LUG	05 - 06
LN 200 SERIES WAFER	07 - 08
T200 SERIES	09
G200 SERIES	10
ESD SERIES ACTUATOR	11
ESA SERIES ACTUATOR	12
TOP WORKS DIMENSIONS	13
TORQUE, FLOW VALUES, & SEAT INFORMATION	14
LEVER, GEAR, & EXTENSION INFORMATION	15
INSTALLATION GUIDE	16
ABOUT OUR COMPANY	



HOW TO ORDER GUIDE

A	B	C	D	E	F	G	H
BF	040	LW	D	D	1	B	1

A	VALVE TYPE
BF	Butterfly Valve

B	SIZE
	INCHES
020	2"
025	2.5"
030	3"
040	4"
050	5"
060	6"
080	8"
100	10"
120	12"
140	14"
160	16"
180	18"
200	20"
240	24"
280	28"
300	30"
360	36"
420	42"
480	48"

C	SERIES
LW	C200 Series Wafer
LL	C200 Series Lug
LR	LR200 Series Wafer
LG	LG200 Series Lug
LN	LN200 Series
SE	T200 Series
GG	G200 Series
DF	Double Flanged

D	DISC MATERIAL
A	Aluminum Bronze
D	Ductile Iron (Ni Plated)
N	Ductile Iron (Nylon Coated)
S	A351 Gr. CF8M (316) Stainless
P	A351 Gr. CF8 (304) Stainless
M	Monel 400®

E	BODY MATERIAL
C	Cast Iron
D	Ductile Iron
S	A351 Gr. CF8M (316) Stainless
W	A216 Gr. WCB (Carbon) Steel

F	STEM MATERIAL
1	416 Stainless
2	316 Stainless
3	304 Stainless Steel
4	Monel K500®

G	SEAT MATERIAL
B	BUNA-N
E	E.P.D.M.
V	F.K.M. (Viton®)
T	P.T.F.E. (Teflon®)
N	Neoprene®
H	Hypalon®

H	ACTUATOR
L	Lever
G	Gear

Wafer and Lug Style Butterfly Valve

C200 Series - Design & Features

The C200 Series is a perfect balance of economy and durability. This general purpose valve is ideal for a wide range of industries including HVAC, oil and gas production, agriculture, chemical and petrochemical, waste water, and mining. The C200 is pressure rated to 200 PSI for sizes 2" to 12" and 150 PSI for sizes 14" to 48".

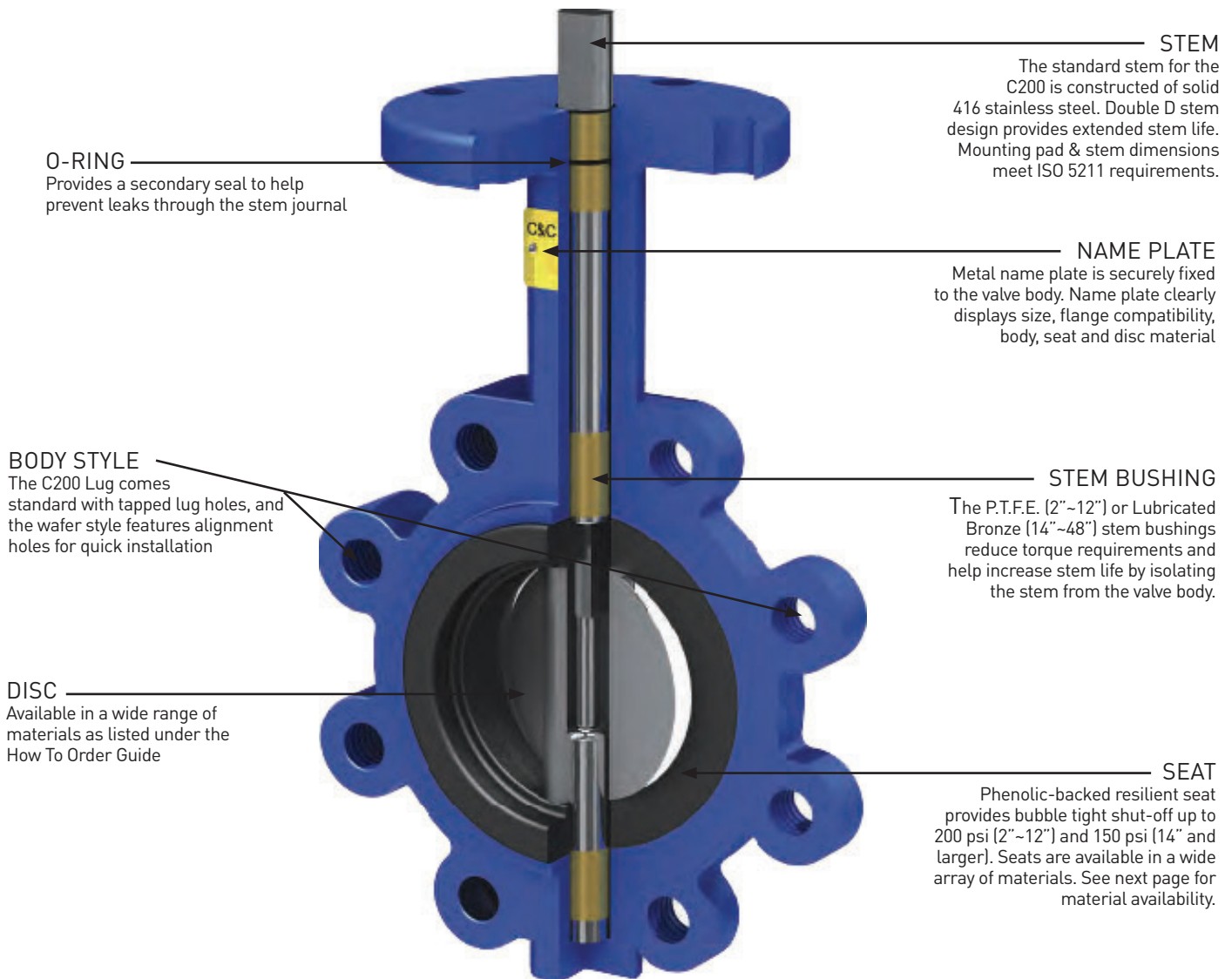

Wafer and Lug Style Butterfly Valve

C200 Series - Dimensional Data

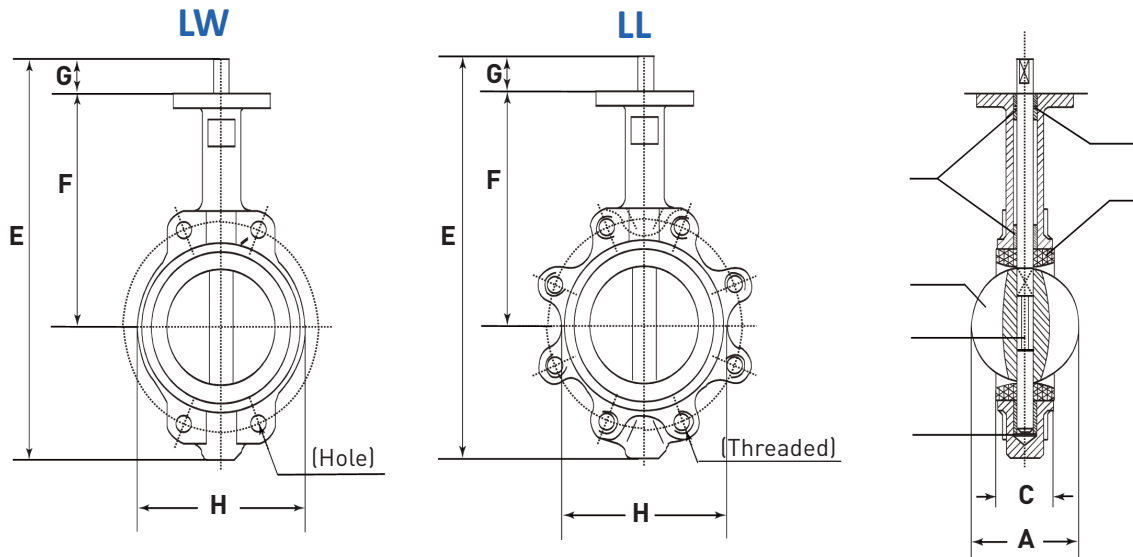

MATERIALS OF CONSTRUCTION

No.	DESCRIPTION	MATERIAL
1	Body	Ductile Iron ASTM A536, WCB Gr 216A*, A351 CF8M*, A351 CF8*
2	Disc	Ductile Iron (Ni Plated), Ductile Iron (Nylon Coated), Aluminum Bronze, CF8M (316 SS), CF8 (304SS)*, Monel**
3	Stem	416 Stainless Steel, 304 Stainless Steel*, 316 Stainless Steel*, Monel** 7.64
4	Seat	194 BUNA-N, E.P.D.M., F.K.M.(Viton®), P.T.F.E. (Teflon®), Neoprene**, Hypalon**
4	O-ring	8.94 BUNA-N (Viton® Optional)
6	Bushing	P.T.F.E. (2"~12"), Lubricated Bronze (14"~24")

*Asterisk denotes factory availability only

DIMENSIONAL DATA

SIZE	A		C		E		F		G		H		WAFER WEIGHT		LUG WEIGHT	
	in	mm	in	mm	in	mm	in	mm	in	mm	in	mm	in	mm	in	mm
2"	2.07	52.60	1.65	42.04	10.74	273.00	6.33	161.00	1.25	32.00	3.94	100.00	8	4	10	5
2.5"	2.53	64.30	1.75	44.68	11.65	296.00	6.88	175.00	1.25	32.00	4.72	120.00	10	5	12	5
3"	3.10	78.80	1.77	45.21	12.12	308.00	7.12	181.00	1.25	32.00	5.00	127.00	11	5	13	6
4"	4.09	104.04	2.05	52.07	13.62	346.00	7.87	200.00	1.25	32.00	6.49	165.00	13	6	21	10
5"	4.85	123.30	2.14	54.36	14.64	372.00	8.38	213.00	1.25	32.00	7.28	185.00	18	8	25	11
6"	6.11	155.38	2.19	55.75	15.62	397.00	8.89	226.00	1.25	32.00	8.34	212.00	20	9	29	13
8"	7.95	202.15	2.38	60.58	18.89	480.00	10.23	260.00	1.77	45.00	10.55	268.00	35	16	48	22
10"	9.84	250.15	2.63	67.00	21.25	540.00	11.49	292.00	1.77	45.00	13.42	341.00	47	21	69	31
12"	11.86	301.45	3.02	76.90	24.17	614.00	13.26	337.00	1.77	45.00	15.74	400.00	77	35	108	49
14"	13.01	330.50	3.01	76.50	26.77	680.00	14.48	368.00	1.77	45.00	17.16	436.00	95	43	158	72
16"	15.33	389.61	3.40	86.50	29.44	748.00	15.74	400.00	2.00	50.80	19.29	490.00	114	52	198	90
18"	17.34	440.51	4.15	105.60	31.02	788.00	16.61	422.00	2.00	50.80	21.22	539.00	191	87	244	111
20"	19.35	491.64	5.18	131.80	36.27	921.50	18.89	480.00	2.26	57.45	23.34	593.00	216	98	271	123
24"	23.32	592.50	5.98	152.00	42.23	1072.80	22.12	562.00	2.75	69.85	31.49	800.00	293	133	392	178

Long Neck Butterfly Valve

LR/LG200 Series - Design & Features

The LR/LG200 Series features an extended neck which allows the mounting pad and stem to clear pipe insulation. This feature makes the LR/LG200 series the logical choice for process and refining applications. The LR/LG200 series also features a two piece stem design that allows for removal and repair of valve parts without special tools or equipment. The LR/LG200 is pressure rated to 200 PSI and is available in sizes 2" through 12".

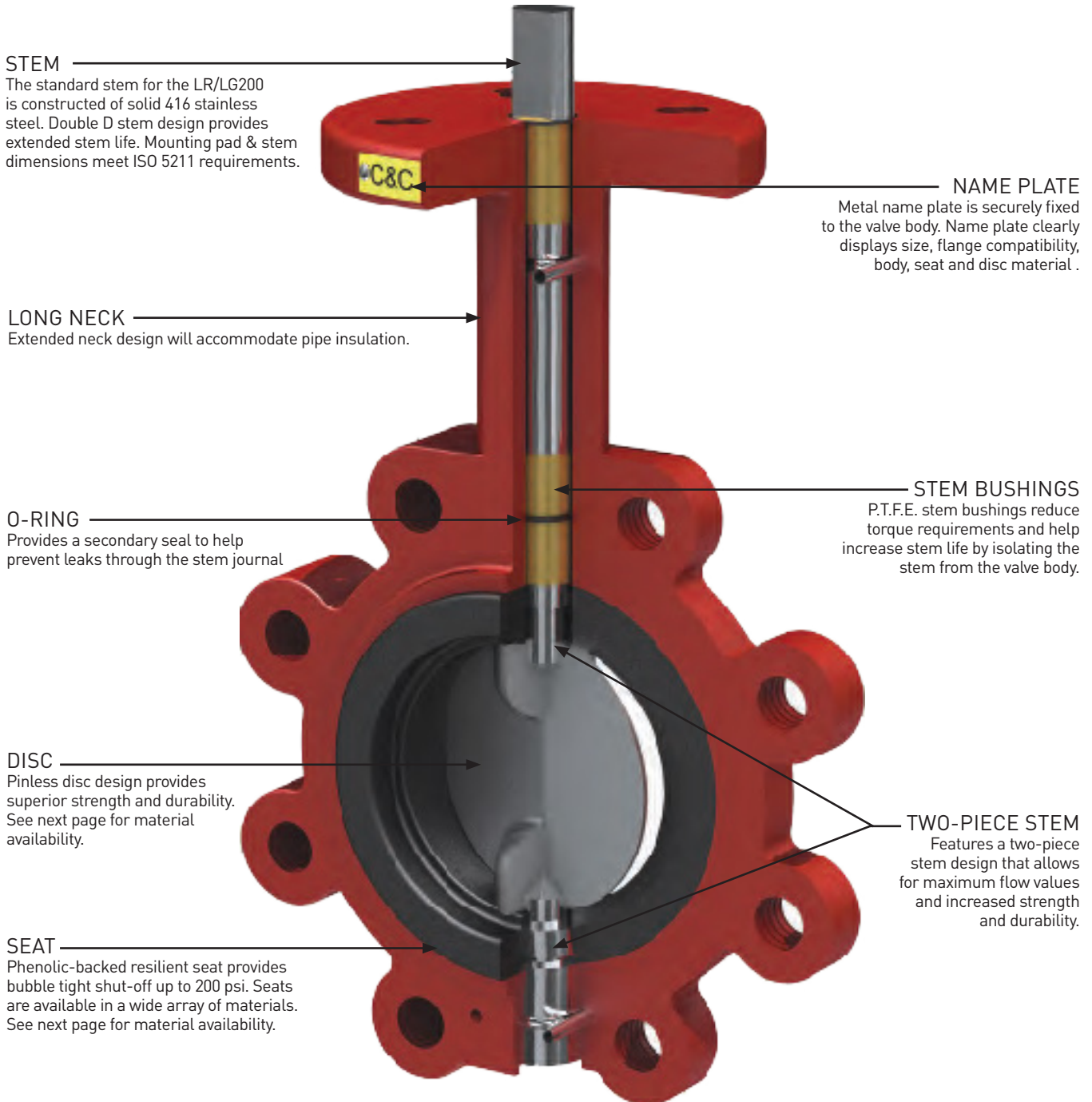

Long Neck Butterfly Valve

LR/LG200 Series - Dimensional Data

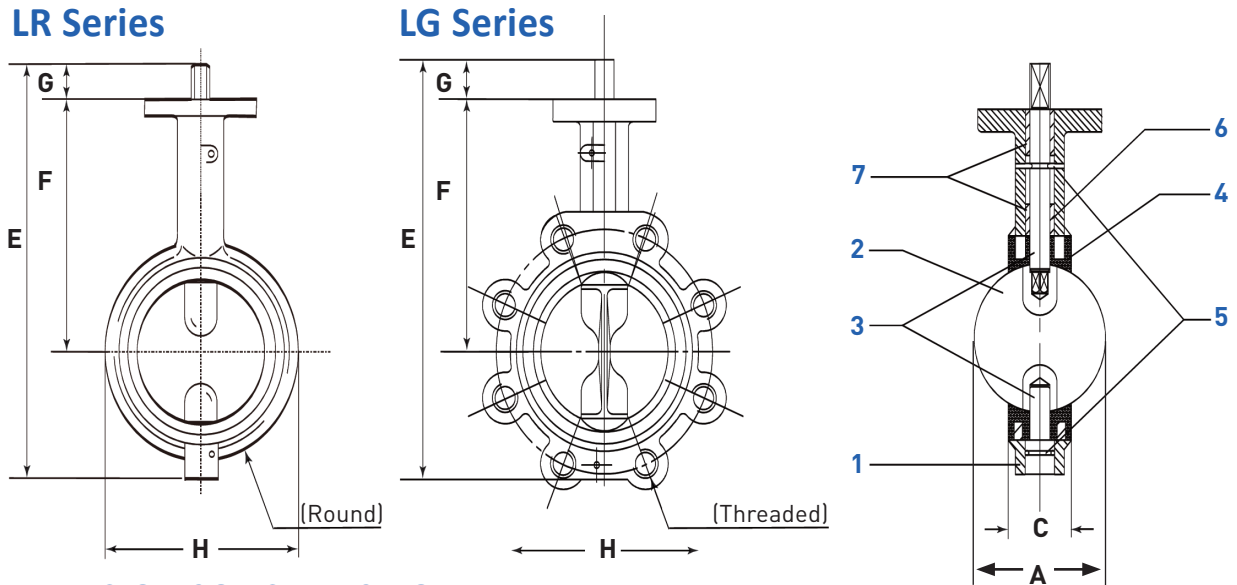

MATERIALS OF CONSTRUCTION

No.	DESCRIPTION	MATERIAL
1	Body	Ductile Iron ASTM A536, WCB Gr 216A*, A351 CF8M*, A351 CF8*
2	Disc	Ductile Iron (Ni Plated), Ductile Iron (Nylon Coated), Aluminum Bronze, CF8M (316 SS), CF8 (304SS)*, Monel**
3	Stem	416 Stainless Steel, 304 Stainless Steel*, 316 Stainless Steel*, Monel**
4	Seat	194 BUNA-N, E.P.D.M., F.K.M.(Viton®), P.T.F.E. (Teflon®), Neoprene®, Hypalon®*
5	Retainer Pin	ASTM Gr. 1065 Steel
6	O-ring	BUNA-N (Viton® Optional)
7	Bushing	P.T.F.E.

*Asterisk denotes factory availability only

DIMENSIONAL DATA

SIZE.	A		C		E		F		G		H		WAFER WEIGHT		LUG WEIGHT	
	in	mm	in	mm	in	mm	in	mm	in	mm	in	mm	in	mm	in	mm
2"	2.07	52.60	1.65	42.04	9.64	245	5.59	142.00	1.25	32.00	3.94	100.00	8	4	10	5
2.5"	2.53	64.30	1.75	44.68	10.43	265	6.12	155.45	1.25	32.00	4.72	120.00	10	5	12	5
3"	3.10	78.80	1.77	45.21	10.94	278	6.37	162.00	1.25	32.00	5.00	127.00	11	5	13	6
4"	4.09	104.04	2.05	52.07	12.24	311	7.11	180.80	1.25	32.00	6.49	165.00	13	6	21	10
5"	4.85	123.30	2.14	54.36	13.34	339	7.74	196.80	1.25	32.00	7.28	185.00	18	8	25	11
6"	6.11	155.38	2.19	55.75	14.48	368	8.25	209.55	1.25	32.00	8.34	212.00	20	9	29	13
8"	7.95	202.15	2.38	60.58	17.32	440	9.44	240.00	1.77	45.00	10.55	268.00	35	16	48	22
10"	9.84	250.15	2.63	67.00	20.47	520	11.25	285.75	1.77	45.00	13.42	341.00	47	21	69	31
12"	11.86	301.45	3.02	76.90	23.46	596	12.18	309.60	1.77	45.00	15.74	400.00	77	35	108	49

Short Neck Butterfly Valve

LN200 Series - Design & Features

The LN200 Series is the perfect choice for work areas with space constraints. Its shorter neck makes the LN200 an ideal valve for trucks, trailers, tanks, or anywhere a compact valve may be desirable. The LN200 is designed with notches in the body, to guide flange bolts during installation, and to keep the valve aligned with the flange during use. The LN200 is designed with a two piece stem which allows for maximum flow values, and for repair of valve parts without special tools. The LN200 is pressure rated to 200 PSI and is available in sizes 2" through 12".

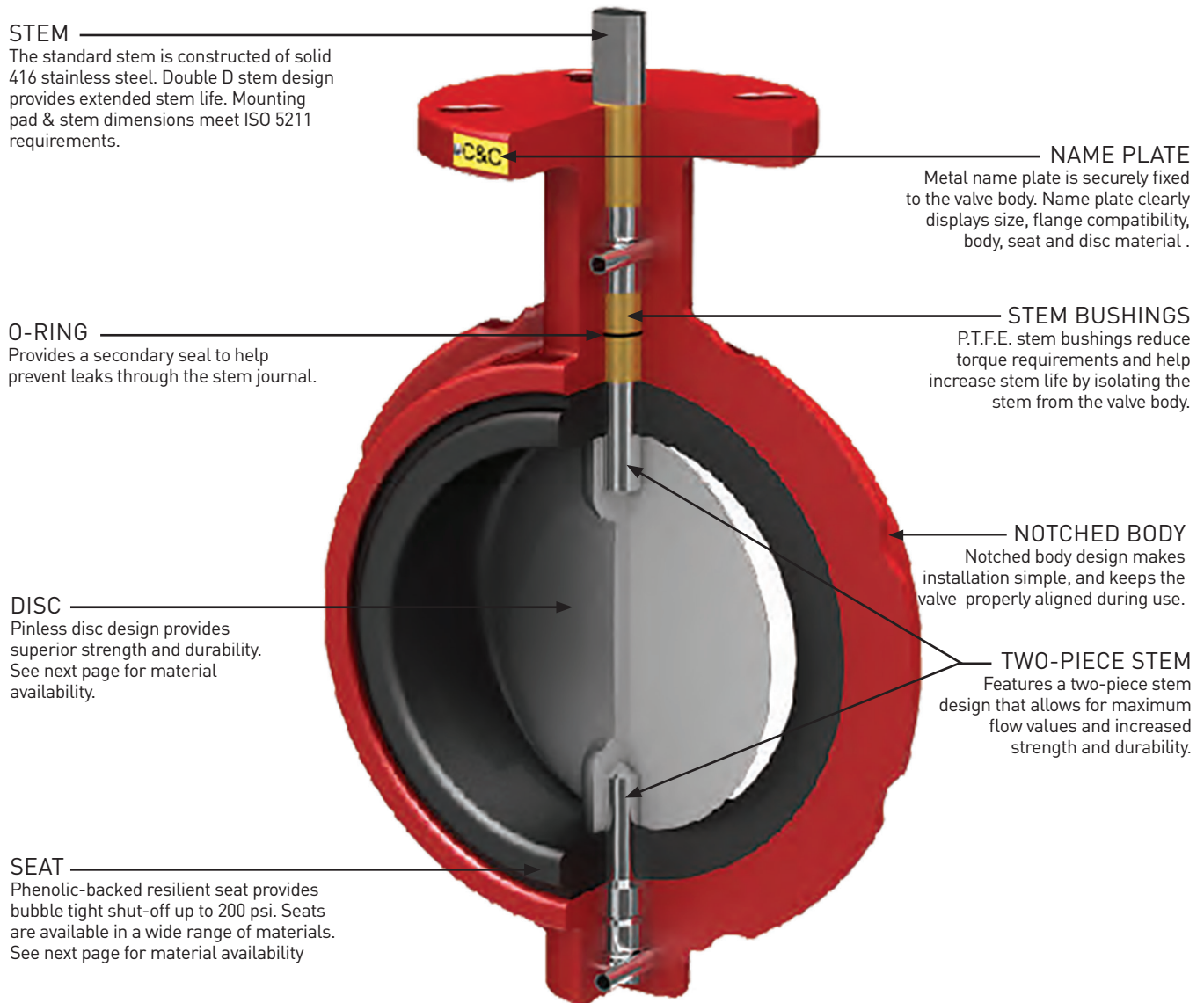

Short Neck Butterfly Valve

LN200 Series - Dimensional Data

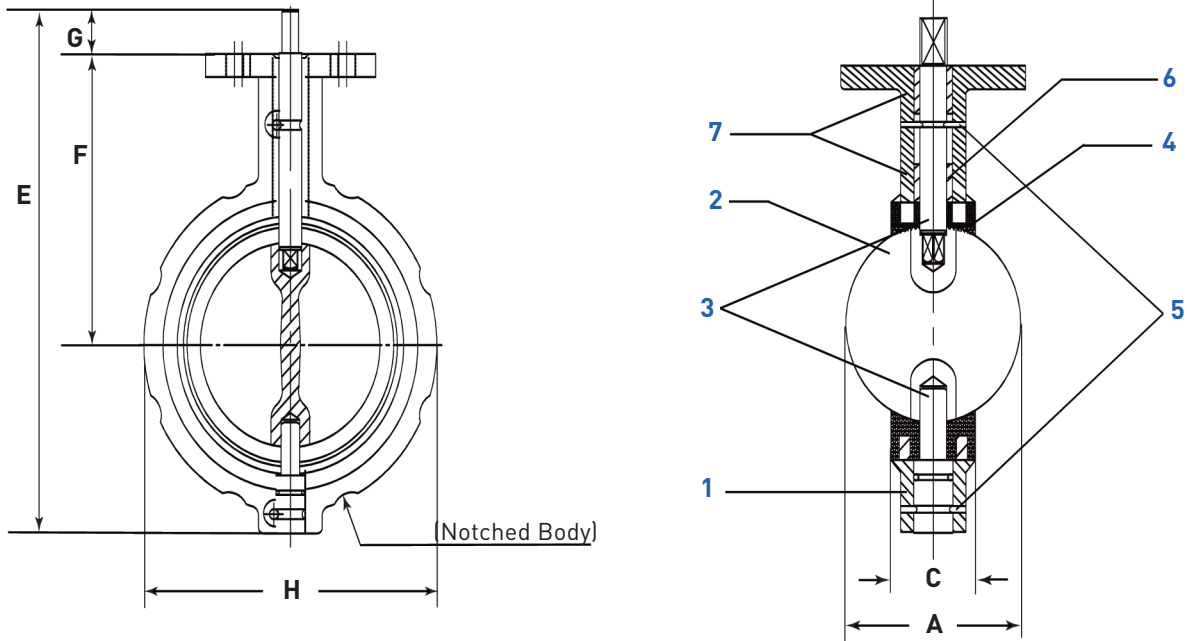

MATERIALS OF CONSTRUCTION

No.	DESCRIPTION	MATERIAL
1	Body	Ductile Iron ASTM A536, WCB Gr 216A*, A351 CF8M*, A351 CF8*
2	Disc	Ductile Iron (Ni Plated), Ductile Iron (Nylon Coated), Aluminum Bronze, CF8M (316 SS), CF8 (304SS)*, Monel®*
3	Stem	416 Stainless Steel, 304 Stainless Steel*, 316 Stainless Steel*, Monel®*
4	Seat	194 BUNA-N, E.P.D.M., F.K.M.(Viton®), P.T.F.E. (Teflon®), Neoprene®, Hypalon®*
5	Retainer Pin	ASTM Gr. 1065 Steel
6	O-ring	BUNA-N (Viton® Optional)
7	Bushing	P.T.F.E.

*Factory availability only

DIMENSIONAL DATA

SIZE	A		C		E		F		G		H		WAFER WEIGHT	
	in	mm	in	mm	in	mm	in	mm	in	mm	in	mm	lbs	Kg
2"	2.07	52.60	1.65	42.04	7.99	203.00	3.93	100.00	1.25	32.00	4.11	104.60	8	4
2.5"	2.53	64.30	1.75	44.68	8.77	223.00	4.44	113.00	1.25	32.00	4.88	124.00	10	5
3"	3.10	78.80	1.77	45.21	9.40	239.00	4.86	123.45	1.25	32.00	5.37	136.60	11	5
4"	4.09	104.04	2.05	52.07	11.14	283.00	5.98	152.00	1.25	32.00	6.87	174.70	13	6
5"	4.85	123.30	2.14	54.36	11.61	295.00	5.98	152.00	1.25	32.00	7.50	190.70	18	8
6"	6.11	155.38	2.19	55.75	12.75	324.00	6.50	165.10	1.25	32.00	8.74	222.20	20	9
8"	7.95	202.15	2.38	60.58	15.94	405.00	8.06	204.73	1.77	45.00	11.00	279.40	35	16
10"	9.84	250.15	2.58	65.63	19.17	487.00	9.97	253.24	1.77	45.00	13.37	339.80	47	21
12"	11.86	301.45	3.02	76.90	22.16	563.00	10.90	277.10	1.77	45.00	15.23	387.00	77	35

Threaded End Butterfly Valve

T200 Series - Design & Features

The T200 Series threaded butterfly valve is the most cost-effective flow control valve for threaded applications. Its simple design allows for smooth operation and long valve life, with minimal maintenance. The T200 features a durable one-piece cast iron body, which is nickel plated for corrosion resistance, and a solid 416 stainless steel stem for superior strength. The T200's simplistic design allows for easy field repair without special tools or equipment. The T200 is pressure rated to 200 PSI and is available in sizes 2"~6" NPT.

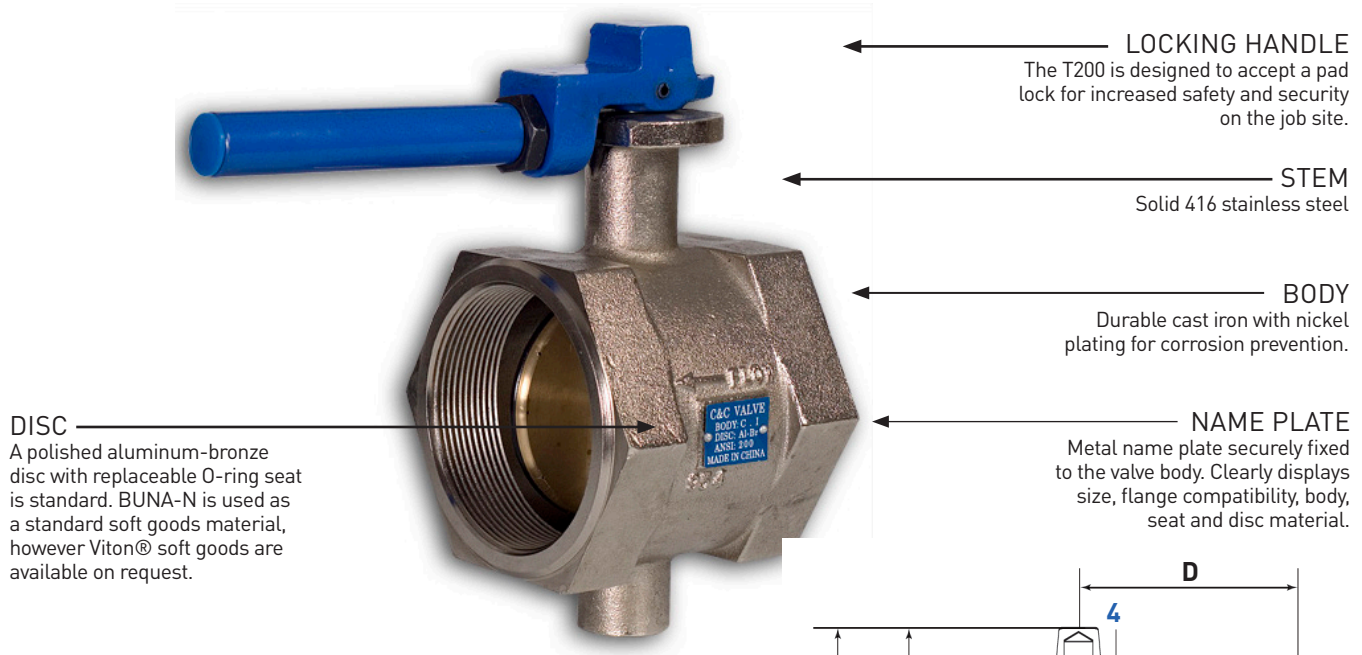

MATERIALS OF CONSTRUCTION

No.	DESCRIPTION	MATERIAL
1	Body	ASTM A126 Cast Iron w/ ENP Plating
2	Disc	Aluminum Bronze
3	Stem	416 Stainless Steel
4	Handle Ball	440DC Stainless Steel
5	Handle	Ductile Iron
6	Stem O-ring	BUNA-N or Viton®
7	Disc O-ring	BUNA-N or Viton®

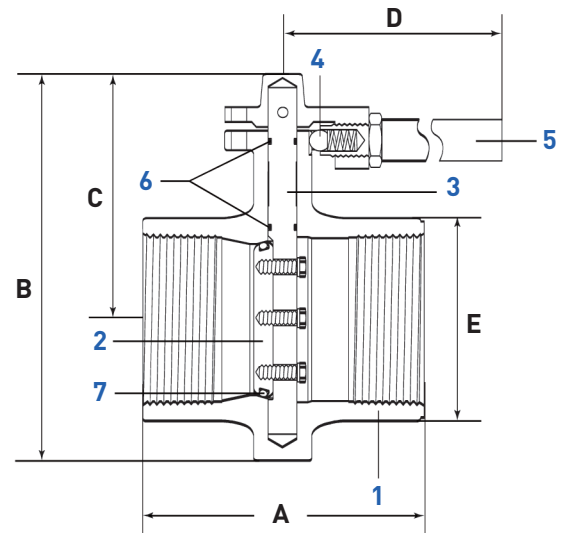

DIMENSIONAL DATA

SIZE.	A		B		C		D		E		WEIGHT		Cv RATE
	in	mm	in	mm	in	mm	in	mm	in	mm	Lbs	Kg	Full Open
2"	4.25	107.95	5.22	132.56	4.15	105.41	8.00	203.20	3.00	76.20	9	4	120
3"	4.87	123.70	8.88	255.76	6.02	152.91	8.00	203.20	4.06	103.12	13	6	270
4"	5.12	130.05	10.03	254.77	6.34	161.04	8.00	203.20	5.31	134.87	19	9	520
6"	7.00	177.80	13.85	351.89	9.10	231.24	13.00	330.20	7.75	196.85	50	23	1300

Grooved End Butterfly Valve

G200 Series - Design & Features

The G200 Series is a grooved end bubble tight shutoff valve with outstanding flow characteristics. The BUNA-N seal is molded onto the ductile iron disc, in order to allow for maximum flow potential. The one-piece body is constructed from durable ductile iron and coated with polymid for corrosion resistance. The G200 is designed to provide bidirectional bubble tight shut off at working pressures up to 200 psi and a working temperature range from 0°~180°F.

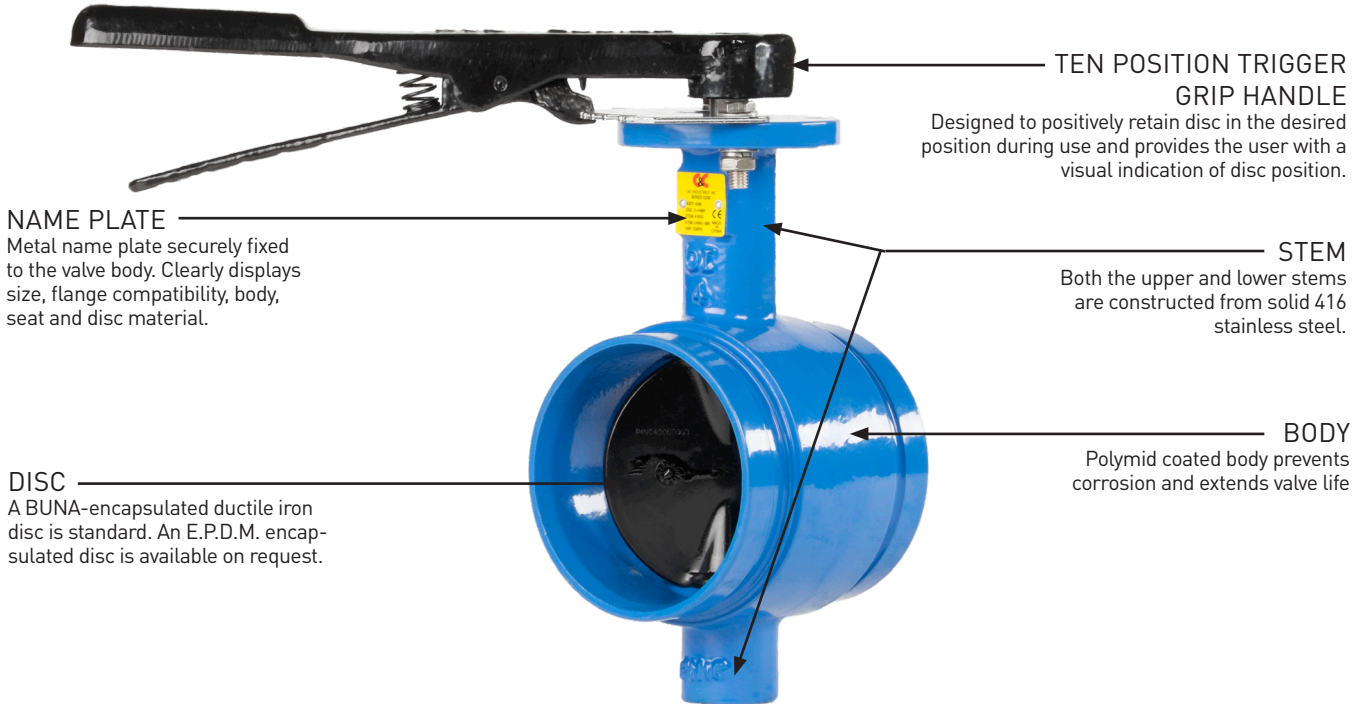

MATERIALS OF CONSTRUCTION

No.	DESCRIPTION	MATERIAL
1	Body	ASTM A-395 Ductile Iron
2	Disc	Ductile Iron Disc Encapsulated w/ BUNA
3	Stem	416 Stainless Steel
4	Stem O-Ring	BUNA or E.P.D.M.

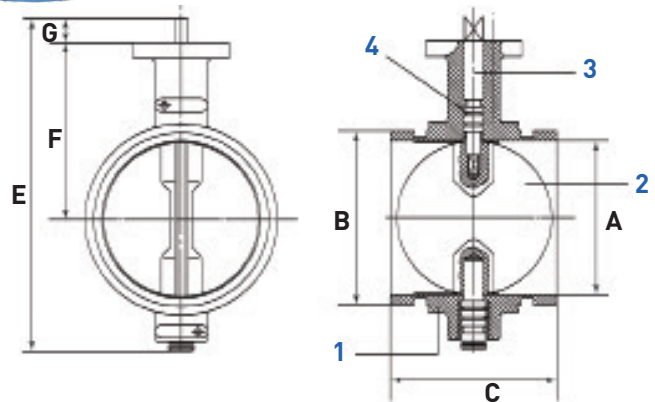

DIMENSIONAL DATA

SIZE	A		B		C		D		E		F		WEIGHT		Cv RATE
	in	mm	in	mm	in	mm	in	mm	in	mm	in	mm	Lbs	Kg	Full Open
2"	2.09	53.10	2.37	60.33	3.20	81.50	8.32	211.50	3.87	98.50	1.25	3200	6	3	170
2.5"	2.55	64.80	2.87	73.03	3.79	96.50	9.02	229.35	4.38	111.35	1.25	32.00	9	4	260
3"	3.12	79.30	3.50	88.90	3.79	96.50	9.80	249.10	4.64	118.10	1.25	32.00	10	5	440
4"	4.11	104.50	4.50	114.30	4.55	115.70	11.17	283.75	5.38	136.75	1.25	32.00	12	6	820
5"	4.87	123.70	5.56	141.30	5.82	148.00	12.13	308.25	5.85	148.75	1.25	32.00	18	8	1200
6"	6.13	155.80	6.62	168.28	5.82	148.00	13.31	338.25	6.38	162.25	1.25	32.00	23	10	1800
8"	7.97	202.60	8.62	219.08	5.27	134.00	16.69	424.00	7.75	197.00	1.77	45.00	40	18	3400

Double Acting Pneumatic Actuator

ESD Series - Design & Features

TOP VIEW

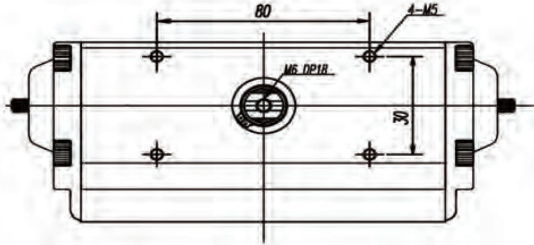

BOTTOM VIEW

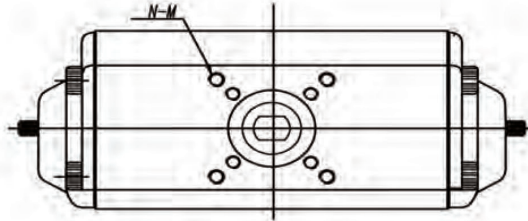

FRONT VIEW

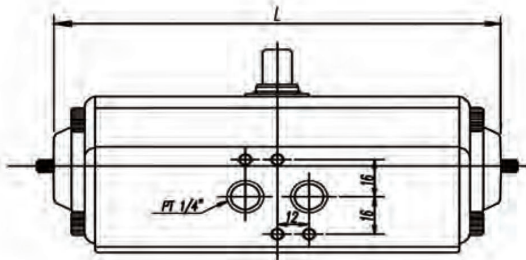

SIDE VIEW

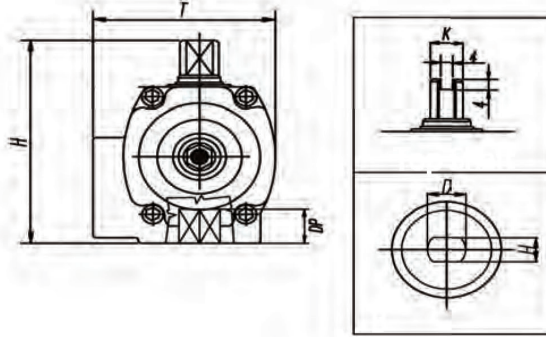

TORQUE OUTPUT

MODEL #	ANGLE	45 PSI	60 PSI	75 PSI	90 PSI	105 PSI	120 PSI
G-ESD-50	0°	270	359	423	539	625	710
	90°	233	314	365	465	538	612
G-ESD-65	0°	588	780	918	1171	1357	1543
	90°	504	669	787	1004	1163	1322
G-ESD-80	0°	1127	1499	1763	2249	2605	2962
	90°	904	1202	1413	1803	2089	2374
G-ESD-100	0°	1808	2404	2827	3605	4177	4750
	90°	1612	2143	2521	3215	3725	4263
G-ESD-125	0°	3990	5303	6237	7953	9216	10161
	90°	3589	4770	5610	7154	8291	9426



DIMENSIONAL DATA

MODEL # & VALVE SIZE	D x H (Bottom Shaft)		L		T		K		H		DP		WEIGHT	
	in	mm	in	mm	in	mm	in	mm	in	mm	in	mm	Lbs	Kg
G-ESD-50 (2"~3")	0.49 x 0.35	12.6 x 9.00	7.40	188.00	2.70	69.00	.43	11.00	3.40	87.00	0.67	17.00	3	1.5
G-ESD-65 (4")	0.62 x 0.43	15.77 x 11.15	9.20	234.00	3.30	83.00	0.51	13.00	4.17	106.00	0.67	17.00	6	2.5
G-ESD-80 (5"~6")	0.74 x 0.50	18.92 x 12.70	11.30	286.00	3.90	98.00	0.67	17.00	4.82	122.50	0.94	24.00	9	4
G-ESD-100 (8")	0.87 x 0.62	22.10 x 15.90	13.50	344.00	4.59	116.50	0.87	22.00	5.60	143.00	1.02	26.00	15	7
G-ESD-100 (10")	1.12 x 0.81	28.45 x 20.62	13.50	344.00	4.59	116.50	0.87	22.00	5.60	143.00	1.02	26.00	15	7
G-ESD-125 (12")	1.24 x 0.94	31.60 x 24.00	17.40	443.00	5.40	137.00	0.87	22.00	6.61	168.00	1.02	26.00	24	11

Spring Return Pneumatic Actuator

ESA Series - Design & Features

TOP VIEW

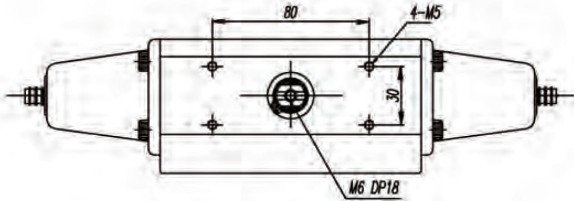

BOTTOM VIEW

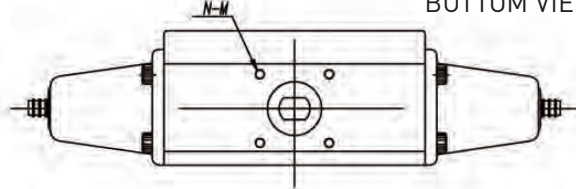

FRONT VIEW

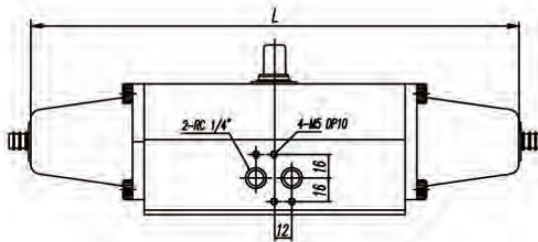

SIDE VIEW

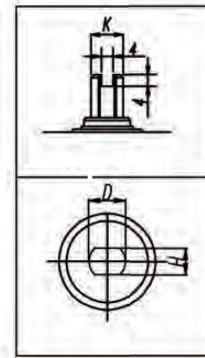
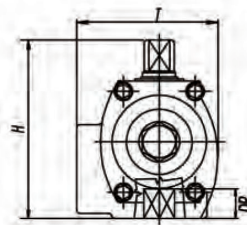

TORQUE OUTPUT

MODEL #	ANGLE	SPRING	45 PSI	60 PSI	75 PSI	90 PSI
G-ESA-50	0°	124	106	195	319	625
	90°	230	---	35	150	195
G-ESA-65	0°	310	257	451	690	779
	90°	478	---	150	389	469
G-ESA-80	0°	531	425	770	1257	1416
	90°	885	35	327	805	947
G-ESA-100	0°	885	876	1460	2390	2673
	90°	1682	---	469	1336	1655
G-ESA-125	0°	2655	1124	2425	4213	4868
	90°	4514	---	177	1965	2567

Torque values in/lbs



DIMENSIONAL DATA

MODEL # & VALVE SIZE	D x H (Bottom Shaft)		L		T		K		H		DP		WEIGHT	
	in	mm	in	mm	in	mm	in	mm	in	mm	in	mm	Lbs	Kg
G-ESA-65 (2"~3")	0.49 x 0.35	12.6 x 9.00	12.60	320.00	3.30	83.00	.51	13.00	4.17	106.00	0.67	17.00	7	3.2
G-ESA-80 (4")	0.62 x 0.43	15.77 x 11.15	16.50	418.00	3.90	98.00	0.59	15.00	4.82	122.50	0.94	24.00	12	5.4
G-ESA-100 (5"~6")	0.74 x 0.50	18.92 x 12.70	19.90	506.00	4.59	116.50	0.87	22.00	5.60	143.00	1.00	26.00	22	10
G-ESA-125 (8")	0.87 x 0.62	22.10 x 15.90	24.41	620.00	5.39	137.00	0.87	22.00	6.61	168.00	1.00	26.00	37	17
G-ESD-140 (10")	1.12 x 0.81	28.45 x 20.62	28.20	716.00	6.06	154.00	0.87	22.00	7.48	190.00	1.20	30.00	53	24
G-ESD-160 (12")	1.24 x 0.94	31.60 x 24.00	32.09	815.00	6.93	176.00	1.26	32.00	8.30	210.00	1.20	30.00	77	35

DESIGN INFORMATION

C200 Series Top Works Data

SIZE	B		D		I		Bolt Circle		Hole Diameter		Number of Bolts
	in	mm	in	mm	in	mm	in	mm	in	mm	
2"	0.49	12.60	3.03	77.00	0.35	9.00	1.97	50.04	0.28	7.11	4
2.5"	0.49	12.60	3.03	77.00	0.35	9.00	1.97	50.04	0.28	7.11	4
3"	0.49	12.60	3.03	77.00	0.35	9.00	1.97	50.04	0.28	7.11	4
4"	0.62	15.77	3.62	92.00	0.43	11.15	2.76	70.10	0.39	9.91	4
5"	0.74	18.92	3.62	92.00	0.50	12.70	2.76	70.10	0.39	9.91	4
6"	0.74	18.92	3.62	92.00	0.50	12.70	2.76	70.10	0.39	9.91	4
8"	0.87	22.10	4.62	125.00	0.62	15.90	4.02	102.11	0.55	13.97	4
10"	1.12	28.45	4.92	125.00	0.81	20.62	4.02	102.11	0.55	13.97	4
12"	1.24	31.60	5.51	140.00	0.94	24.00	4.02	102.11	0.55	13.97	4
14"	1.24	31.60	5.51	140.00	0.94	24.00	4.02	102.11	0.55	13.97	4
16"	1.30	33.15	7.75	197.00	1.06	27.10	5.51	139.95	0.71	18.03	4
18"	1.49	38.00	7.75	197.00	1.06	27.10	5.51	139.95	0.71	18.03	4
20"	1.62	41.15	7.75	197.00	1.26	32.10	6.49	164.85	0.71	18.03	4
24"	1.99	50.65	10.86	276.00	1.42	36.10	6.49	164.85	0.91	23.11	4

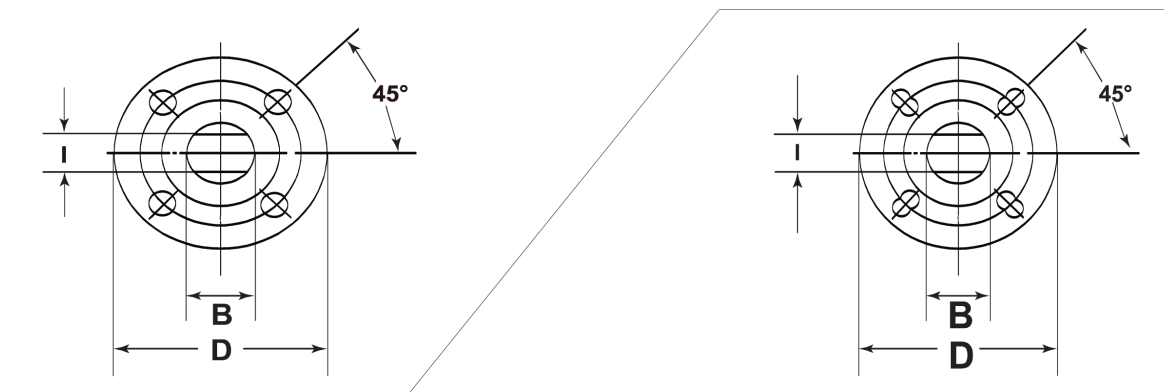

LR, LG & LN200 Series Top Works Data

SIZE	B		D		I		Bolt Circle 1		Bolt Circle 2		Hole Diameter		Number of Bolts
	in	mm	in	mm	in	mm	in	mm	in	mm	in	mm	
2"	0.49	12.60	4.00	101.60	0.35	9.00	2.76	70.00	3.25	82.55	0.408	10.36	4
2.5"	0.49	12.60	4.00	101.60	0.35	9.00	2.76	70.00	3.25	82.55	0.408	10.36	4
3"	0.49	12.60	4.00	101.60	0.35	9.00	2.76	70.00	3.25	82.55	0.408	10.36	4
4"	0.62	15.77	4.00	101.60	0.43	11.15	2.76	70.00	3.25	82.55	0.408	10.36	4
5"	0.74	18.92	4.00	101.60	0.50	12.70	2.76	70.00	3.25	82.55	0.408	10.36	4
6"	0.74	18.92	4.00	101.60	0.50	12.70	2.76	70.00	3.25	82.55	0.408	10.36	4
8"	0.87	22.10	6.00	152.40	0.62	15.90	4.02	102.11	5.00	127.00	0.533	0.533	4
10"	1.12	28.45	6.00	152.40	0.81	20.62	4.02	102.11	5.00	127.00	0.533	0.533	4
12"	1.24	31.60	6.00	152.40	0.94	24.00	4.02	102.11	5.00	127.00	0.533	0.533	4

DESIGN INFORMATION

C200 Torque Values

SIZE	Differential Pressure			
	50 PSI	100 PSI	150 PSI	200 PSI
2"	139	148	156	164
2.5"	195	207	218	230
3"	264	278	293	307
4"	371	401	431	461
5"	579	627	676	725
6"	875	946	1016	1087
8"	1476	1559	1642	1726
10"	2451	2613	2775	2937
12"	3900	4111	4323	4534
14"	5189	5467	5744	6022
16"	10985	11569	12154	12738
18"	13946	14688	15431	16173
20"	14695	15478	16260	17043
24"	29738	31321	32903	34486

Torque values in/lbs

C200 Flow Coefficient

SIZE	Disc Position / Cv Rate									
	90°	80°	70°	60°	50°	40°	30°	20°	10°	
2"	100	91	61	38	23	13	8	3	0.60	
2.5"	170	158	103	65	39	22	10	5	0.1	
3"	261	238	158	115	70	34	16	8	0.2	
4"	519	472	314	199	120	68	31	15	0.3	
5"	884	904	536	339	205	115	53	25	0.5	
6"	1366	1243	829	523	317	177	82	30	0.8	
8"	2713	2460	1646	1040	629	353	163	77	2	
10"	4819	4203	2803	1771	1070	600	277	131	3	
12"	7136	6494	4329	2735	1663	927	428	202	4	
14"	10308	9380	6254	3951	2338	1340	618	282	5	
16"	14176	12900	8600	5434	3284	1842	850	401	7	
18"	18775	17805	11390	7157	4340	2441	1126	532	10	
20"	24140	21968	14645	95254	5592	3138	1448	684	12	
24"	37295	33930	22623	14297	8640	4848	2238	1057	19	

LR, LG & LN200 Torque Values

SIZE	Differential Pressure			
	50 PSI	100 PSI	150 PSI	200 PSI
2"	108	119	125	132
2.5"	108	173	182	192
3"	192	270	285	300
4"	264	405	428	450
5"	450	630	665	700
6"	550	810	855	900
8"	1000	1350	1425	1500
10"	1800	2385	2518	2650
12"	3000	4050	4275	4500

LR, LG & LN200 Flow Coefficient

SIZE	Disc Position / Cv Rate									
	90°	80°	70°	60°	50°	40°	30°	20°	10°	
2"	145	115	70	53	27	17	9	4	0.07	
2.5"	225	175	105	83	42	26	15	8	0.2	
3"	325	260	160	125	63	38	22	11	0.3	
4"	590	510	305	235	120	73	42	21	0.4	
5"	1125	1000	625	490	250	155	88	42	0.8	
6"	1950	1650	1030	800	410	250	145	54	1.4	
8"	3250	2725	1750	1300	700	420	250	118	3.0	
10"	5000	4300	2750	2150	1150	670	390	185	4.2	
12"	7500	6050	4050	3100	1600	1000	550	260	5.1	

Seat Insert Information

Material: Nitrile

Trade Name: BUNA-N

Temperature Range: (0°F~180°F)

Information: BUNA-N is accepted industry-wide as the best general purpose material for seats and seals. The low cost of BUNA-N, its resistance to most hydrocarbons, and its wide temperature range, make it the logical choice for most oil & gas applications.

Material: E.P.D.M.

Trade Name: Vistalon®

Temperature Range: (-30°F~250°F)

Information: E.P.D.M. is the most cost effective seat/seal material for hot water or steam applications; conversely, its low-end temperature range and compatibility with most types of glycol allow it to be used in many HVAC applications. E.P.D.M. is not compatible with hydrocarbons.

Material: F.K.M

Trade Name: Viton B®

Temperature Range: (14°F~300°F)

Information: Fluoroelastomers have a field-proven reputation of providing excellent resistance to a wide range of corrosive chemicals, even when elevated temperatures are present. Fluoroelastomers are not compatible with hot water or steam.

Material: P.T.F.E.

Trade Name: Teflon®

Temperature Range: (-30°F~250°F)

Information: Its wide temperature range, broad chemical resistance, and low coefficient of friction have made P.T.F.E. a staple in the oilfield, industrial, and food service industries.

Manual Actuators

Lever Dimensional Data

SIZE	A		B		WEIGHT	
	in	mm	in	mm	Lbs	Kg
2" ~ 3"	9.44	240	1.25	32	1.10	0.5
4" ~ 6"	10.43	265	1.25	32	1.76	0.8
8"~12"	14.40	366	1.77	45	2.87	1.3

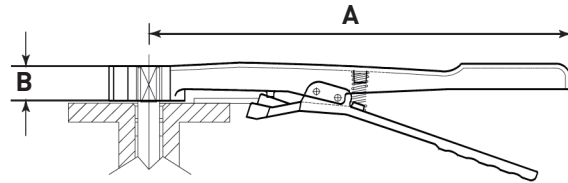

Gear Dimensional Data

SIZE	A		B		C		D		WEIGHT	
	in	mm	in	mm	in	mm	in	mm	Lbs	Kg
2"	6.18	157.00	0.35	9.04	1.96	50.00	5.90	150.00	13	6
2.5"	6.18	157.00	0.35	9.04	1.96	50.00	5.90	150.00	13	6
3"	6.18	157.00	0.35	9.04	1.96	50.00	5.90	150.00	13	6
4"	6.18	157.00	0.44	11.30	2.75	70.00	5.90	150.00	13	6
5"	6.18	157.00	0.50	12.90	2.75	70.00	5.90	150.00	13	6
6"	6.18	157.00	0.50	12.90	2.75	70.00	5.90	150.00	13	6
8"	9.37	238.00	0.63	16.10	4.01	102.00	11.81	300.00	19	9
10"	9.37	238.00	0.81	20.8	4.01	102.00	11.81	300.00	19	9
12"	8.89	226.00	0.95	21.18	4.01	102.00	11.81	300.00	40	18
14"	8.89	226.00	0.95	24.18	4.01	102.00	11.81	300.00	40	18
16"	10.62	270.00	1.07	27.18	5.51	140.00	11.81	300.00	66	30
18"	10.90	277.00	1.07	27.18	5.51	140.00	11.81	300.00	66	30
20"	13.30	338.00	1.26	32.18	5.51	140.00	11.81	300.00	159	72
24"	13.30	338.00	1.42	36.17	6.49	165.00	11.81	300.00	159	72

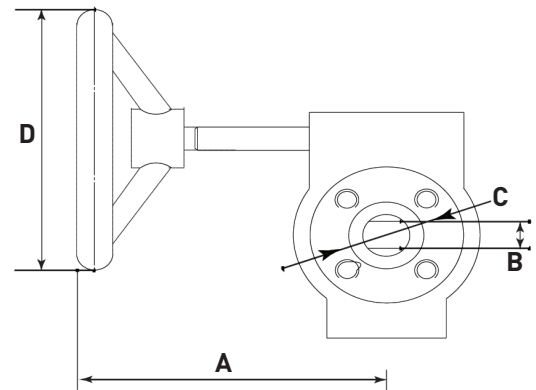

Extension Dimensional Data

SIZE	A		B		C		D
	in	mm	in	mm	in	mm	in
2"	3.03	77.00	1.25	32.00	0.49	12.60	24" ~ 72"
2.5"	3.03	77.00	1.25	32.00	0.49	12.60	24" ~ 72"
3"	3.03	77.00	1.25	32.00	0.49	12.60	24" ~ 72"
4"	3.62	92.00	1.25	32.00	0.62	15.77	24" ~ 72"
5"	3.62	92.00	1.25	32.00	0.74	18.92	24" ~ 72"
6"	3.62	92.00	1.25	32.00	0.74	18.92	24" ~ 72"
8"	4.92	125.00	1.77	45.00	0.87	22.10	24" ~ 72"
10"	4.92	125.00	1.77	45.00	1.12	28.45	24" ~ 72"
12"	5.51	140.00	1.77	45.00	1.24	31.60	24" ~ 72"
14"	5.51	140.00	1.77	45.00	1.24	31.60	24" ~ 72"
16"	7.75	197.00	2.00	50.80	1.30	33.15	24" ~ 72"
18"	7.75	197.00	2.00	50.80	1.49	38.00	24" ~ 72"
20"	7.75	197.00	2.25	57.15	1.63	41.45	24" ~ 72"
24"	10.86	276.00	2.75	69.85	1.99	50.65	24" ~ 72"

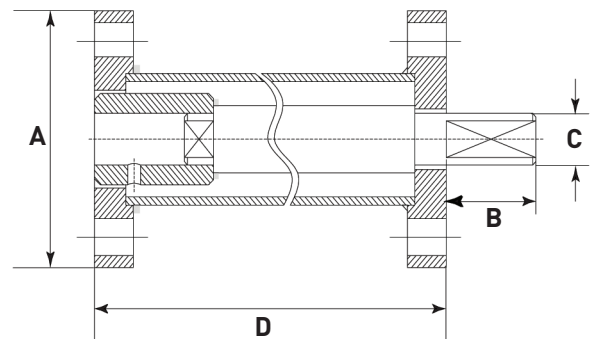

INSTALLATION GUIDE

Instructions

1. Align pipe flanges accurately in the line. Insure that there is enough space between the flanges to accommodate the valve.
2. Clear the flange of any foreign material, and inspect flange faces for any damage.
3. Insert the valve between the flanges carefully so as not to damage the seat and/or flange faces. Use of lubricant is not recommended, as some lubricants may damage seat materials.
4. Align the valve with the flanges, select desired type of bolting shown in "Figure A/B/C", and insert the recommended bolts as shown in "Figure 3". Tighten the bolts enough to hold the valve in place.
5. Operate the valve to ensure that the disc will clear the inside of the pipe and that the lever/gear will clear any nearby obstacles. When gear-operated valves are installed, move the valve to full open, and full closed, positions to ensure that the gear stops have been properly set.
6. Once proper valve operation has been confirmed, open valve to position 2 (20°), and tighten the bolts with the recommended amount of force shown in "Figure 1". Bolts should be tightened in an alternating pattern shown in "Figure 2".

Caution:

- C&C Butterfly Valves are designed to fit ANSI 125 flat faced & ANSI 150 raised face flanges only.
- C&C Butterfly Valves are not compatible with rubber faced or mechanical flanges.
- Verify compatibility of valve materials with flow medium. Improper selection of valve materials could cause failure of valve, and subsequent injury of personnel.
- C&C Butterfly valves are not designed to be welded. No weld repair should be preformed on a C&C Butterfly valve.
- Only C&C parts should be used to repair a C&C valve.
- Gear operators are recommended for sizes 12" and larger.
- E.P.D.M. seats should not be used with any oil/petroleum based products or compressed air.
- F.K.M. (Viton®) and BUNA seats are not acceptable for steam service.

Figure 1

Valve Size	Recommended Bolt Torque	Valve Size	Recommended Bolt Torque
2" ~ 4"	240 - 360 in-lb	14" ~ 16"	1680 - 2400 in-lb
5" ~ 8"	396 - 600 in-lb	18" ~ 20"	1800 - 2520 in-lb
10"	696 - 900 in-lb	24" ~ 30"	2580 - 3600 in-lb
12"	960 - 1320 in-lb		

Figure 3

VALVE SIZE	Bolt Diameter	Number of Bolts Req.		Stud Bolt Length "A"	All Thread Length "B"	Cap Screw Length "C"
		Fig A & B	Fig C			
2"	5/8" ~ 11 UNC	4	8	4"	5"	1 1/4"
2.5"	5/8" ~ 11 UNC	4	8	4 1/4"	5 1/4"	1 1/2"
3"	5/8" ~ 11 UNC	4	8	4 1/2"	5 1/4"	1 1/2"
4"	5/8" ~ 11 UNC	8	16	5"	6"	1 3/4"
5"	3/4" ~ 10 UNC	8	16	5 1/2"	6 1/2"	1 3/4"
6"	3/4" ~ 10 UNC	8	16	5 1/2"	6 3/4"	2"
8"	3/4" ~ 10 UNC	8	16	6"	7"	2 1/4"
10"	7/8" ~ 9 UNC	12	24	6 3/4"	8"	2 1/4"
12"	7/8" ~ 9 UNC	12	24	7"	8 1/4"	2 1/2"
14"	1" ~ 8 UNC	12	24	7 1/2"	8 1/2"	2 3/4"
16"	1" ~ 8 UNC	16	32	8"	9 1/2"	3 1/4"
18"	1 1/8" ~ 7 UNC	16	32	9"	10 1/2"	3 1/2"
20"	1 1/8" ~ 7 UNC	20	40	9 1/2"	11"	4"
24"	1 1/4" ~ 7 UNC	20	40	11"	12 1/2"	4 3/4"

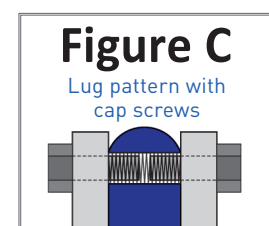
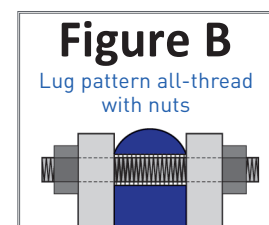
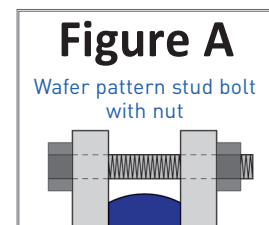
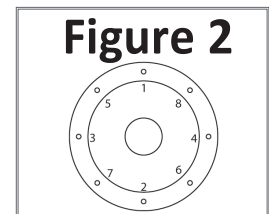

About Our Company



CNC Flow Control is headquartered in Houston, Texas with multiple other locations in the U.S. and Canada. Our company unifies several trusted valve and flow line brands that have been serving numerous industries in North America for nearly three decades. From long range projects to same-day delivery, our diverse team is dedicated to understanding customers' needs in order to ensure exceptional service and the best solutions. Our extensive product portfolio ranges from commodity products like hammer unions and needle valves, to highly engineered products like API 6D trunnion mounted ball valves.



Quality assurance is critical to CNC Flow Control's process and we hold multiple internationally recognized quality standards certifications and management system. We are dedicated to understanding our customers' needs to ensure exceptional service by offering an in-house engineering and product management team, an extremely large product portfolio and extensive inventory to support same day shipments.

Permian Basin

1100 W IH 20
Odessa, TX 79763
Main Phone: 432.276.7640

Headquarters

10350 Clay Road, Suite 250
Houston, TX 77041
Toll-Free: 844.398.6449
Fax: 713.466.1715

Canada

2930 51 Avenue NW, Unit # 3
Edmonton, AB T6P 0E1
Main Phone: 780.462.9166

Website: www.cncflowcontrol.com

Follow us:

