

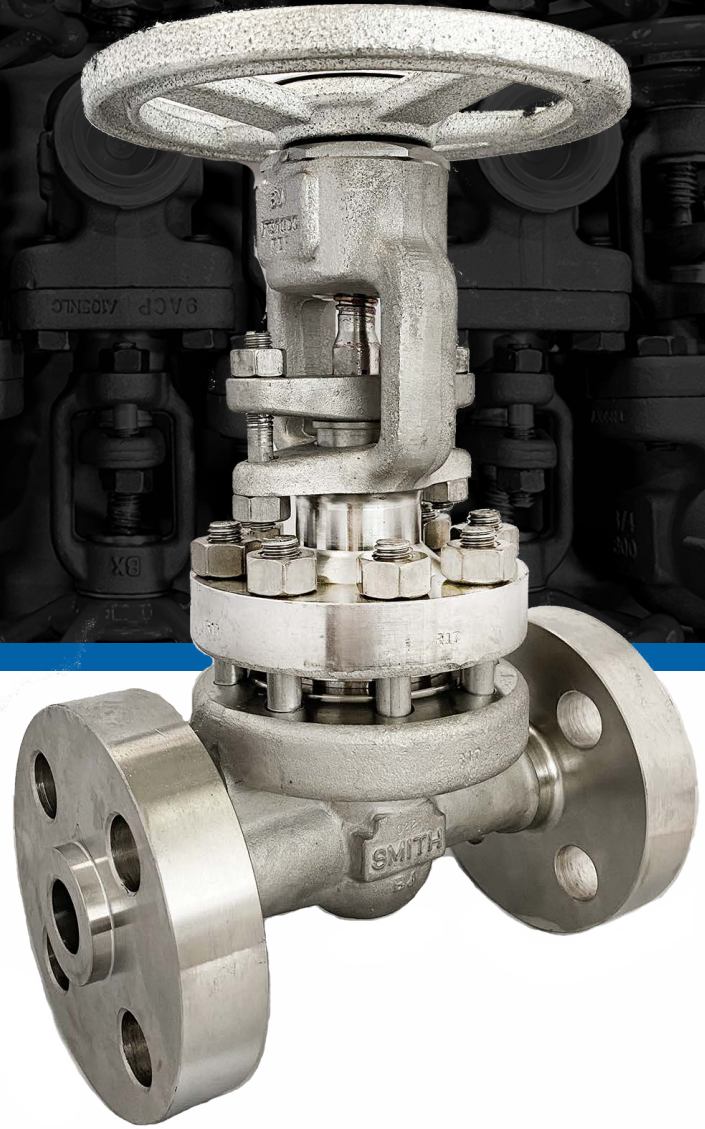

**SMITH  
VALVES**



# FORGED STEEL VALVES

GATE / GLOBE / CHECK

---

SALES@SMITHVALVES.COM



713.590.1312



13750 HOLLISTER RD. HOUSTON, TX

[WWW.SMITHVALVES.COM](http://WWW.SMITHVALVES.COM)

A REPUTATION FOR QUALITY AND SERVICE  
THAT HAS BEEN **FORGED** OVER A SOLID  
HALF CENTURY...



# CONTENTS

05 - 07.....	PORTFOLIO & PRODUCT OVERVIEW
08 - 16.....	STANDARD GATE VALVES
17 - 19.....	EXTENDED BODY GATE VALVES
20 - 26.....	BELLOWS SEAL GATE VALVES
27 - 29.....	CRYOGENIC GATE VALVES
30 - 35.....	STANDARD GLOBE VALVES
36 - 41.....	BELLOWS GLOBE VALVES
42 - 44.....	CRYOGENIC GLOBE VALVES
45 - 47.....	Y-PATTERN GLOBE VALVES (BOLTED & WELDED BONNET)
48 - 49.....	Y-PATTERN GLOBE VALVES (BONNETLESS)
50 - 55.....	PISTON CHECK VALVES
56 - 61.....	BALL CHECK VALVES
62 - 64.....	SWING CHECK VALVES
65.....	UNION BALL CHECK VALVES
66 - 68.....	Y-PATTERN CHECK VALVES - BOLTED & WELDED CAP
69.....	Y-PATTERN CHECK VALVES - THREADED CAP
70 - 71.....	PART NUMBERING SYSTEM
72 - 73.....	STYLE CODE INDEX
74.....	HANDWHEEL COLOR CODING
75.....	NOTES



# OUR STORY

1956

## THE BEGINNING

Smith Valves was founded by James Dewolf Smith in 1956 to produce forged gate, globe, and check valves for use primarily in the petrochemical industry. By the mid-1970s, the company had become one of the industry's largest producers of industrial gate, globe, check and ball valves under the 2.5" size. Soon thereafter, exotic stainless and alloy components were added to the product line.

2011

## THE END OF AN ERA

In March of 2000, the Newdell Company bought Smith and moved production to Italy. Six years later operations returned to the United States in Houston, Texas. In 2011, ERIKS acquired the Newdell Company as part of its strategy to build a comprehensive platform for flow technology in North America. CNC Flow Control was created in 2017 as part of this initiative and Smith became a brand under the CNC Flow Control Group.

2020

## NEW BEGINNINGS

In October 2020, Smith Valves Company, LLC purchased the trademarks and all assets related to Smith Valves from CNC Flow Control. Smith continues its customer-driven focus as a globally approved brand with a proven reputation of excellence in quality and service.



## PRODUCT PORTFOLIO

Smith Valves is one of the oldest valve brands for API 602 forged steel valves in the industry today. Producing a broad range of gate, globe and check valves utilized in the oil and gas, refinery, petrochemical and many other industries throughout the world, Smith delivers!

GATE • GLOBE • CHECK •  
BELLOWS SEAL • CRYOGENIC  
Y-PATTERN

FORGED STEEL

THREADED ENDS  
SOCKETWELD ENDS  
FLANGED ENDS  
BUTTWELD ENDS

RISING HANDWHEEL  
NON-RISING HANDWHEEL

SOLID WEDGE DISC  
PLUG DISC

1/2" - 3"  
CL150 - CL4500

CARBON STEEL  
STAINLESS STEEL • CHROME  
ALLOY 20 • DUPLEX  
HIGH NICKEL ALLOY



# FORGED PRODUCTS

## FOR THE PETROCHEMICAL MARKET

Smith stocks API 602 multi-turn valves in a variety of materials from carbon steel to nickel alloy and pressure classes ranging from 150 to 4500. In addition, both reduced and full ports and welded and bolted bonnet designs are available. Our facility allows for inventory storage and automated retrieval with our custom ASRS system.

We conduct in-house testing with NDE capabilities and a fully integrated machine shop. This allows for quick deliveries and unconventional customer requirements to be met in a timely, quality controlled manner. On-site testing capabilities include bellows testing per MSS SP-117, cryogenic testing, API-598 pressure testing and liquid dye penetrant testing. With low emission requirements as a basis, Smith Valves offers our complete line of forged products with API 624 certification.

Our facility carries a certified ISO-9001 quality system, CE-PED certification and an API 602 designation.

- 
- **API 602, ASME B16.34**
  - **Bolted & Welded Bonnet Available**
  - **Full & Reduced Port Available**
  - **Threaded, Socketweld, Buttweld, Flanged Ends Available**
  - **API 622 & API 624 Qualified Packing for Low Fugitive Emissions**

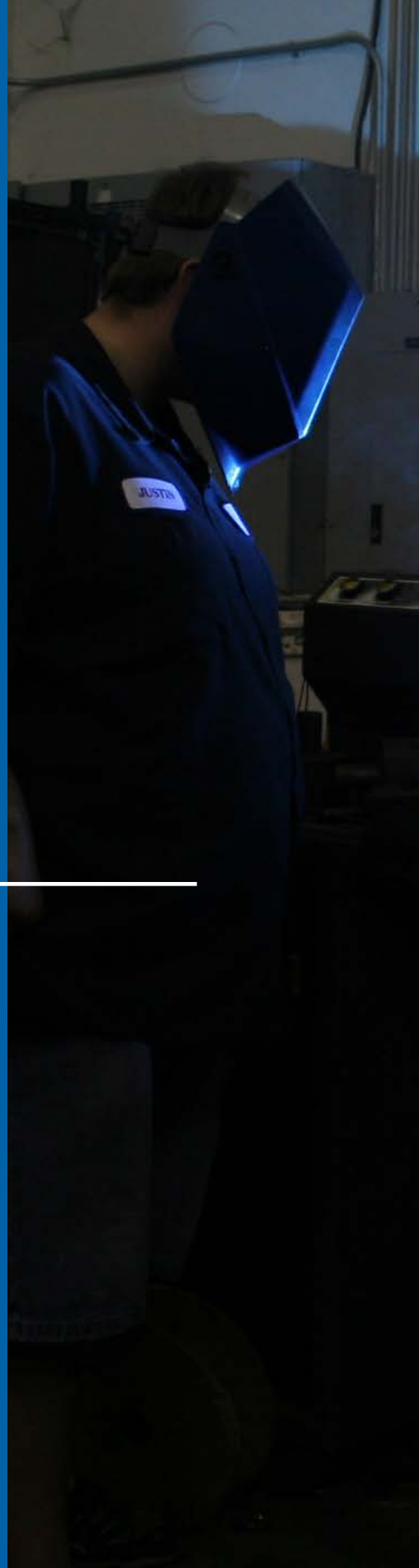

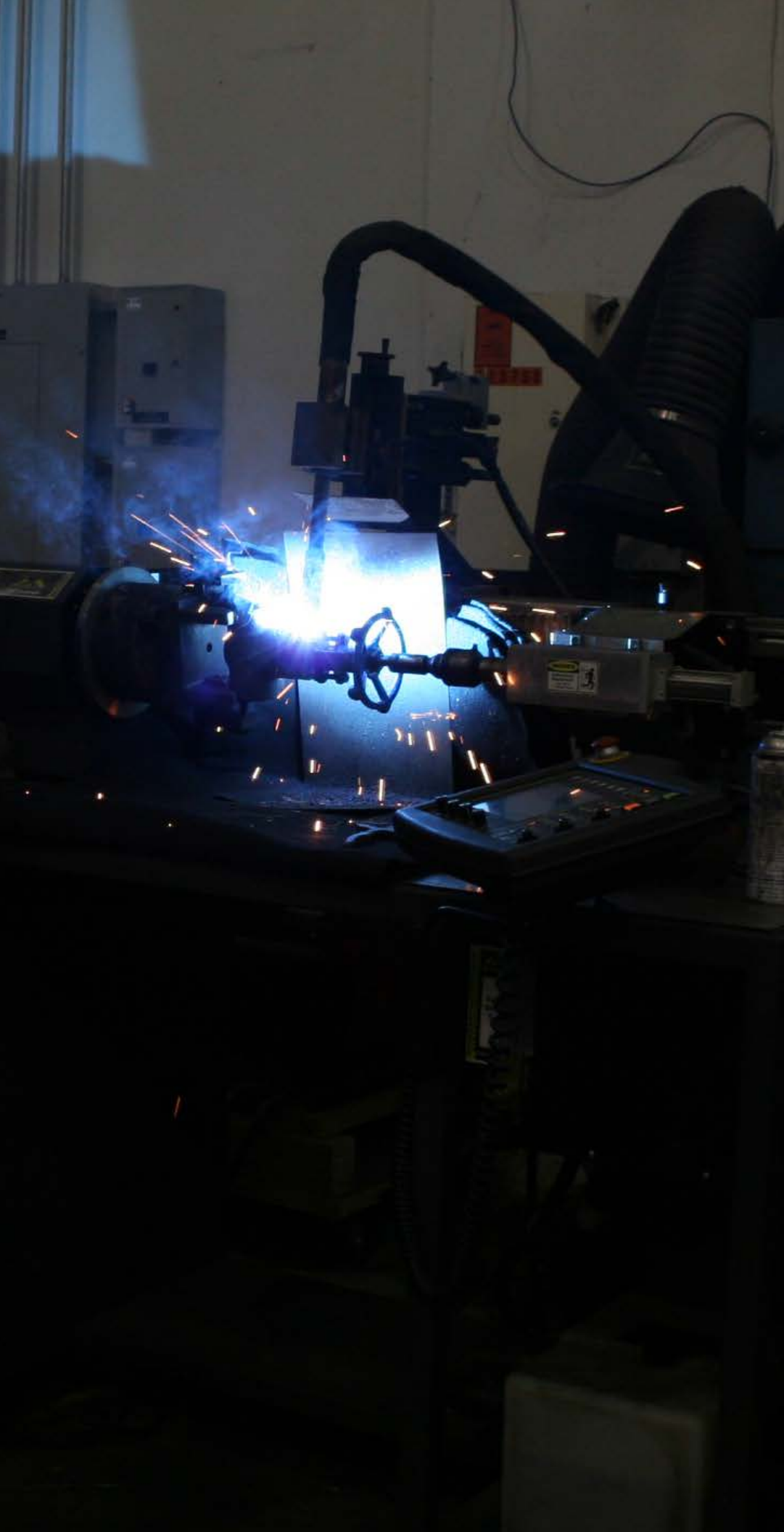

**GATE**

**EXTENDED BODY GATE**

**BELLOWS SEAL GATE**

**CRYOGENIC GATE**

**GLOBE**

**BELLOWS SEAL GLOBE**

**CRYOGENIC GLOBE**

**Y-PATTERN GLOBE**

**CHECK**

**Y-PATTERN CHECK**

# GATE VALVES



## DESIGN & CONSTRUCTION

- API 602, ASME B16.34
- Bolted & welded bonnet
- Reduced and full port
- Threaded, Socketweld, Buttweld ends class 800 to 2500
- Flanged ends class 150 to 2500
- Bonnet constructed of forged steel with integral backseat
- Nameplate serialized for full traceability
- API 622 and API 624 qualified packing for low emissions

- 01 STEM
- 02 HANDWHEEL
- 03 BONNET
- 04 GLAND STUD NUT
- 05 GLAND STUD
- 06 BONNET BOLT
- 07 BODY
- 08 HANDWHEEL NUT
- 09 LOCK WASHER
- 10 NAMEPLATE
- 11 THRUST WASHER
- 12 YOKE NUT
- 13 GLAND FLANGE
- 14 GLAND
- 15 PACKING
- 16 GASKET
- 17 WEDGE
- 18 SEAT RING

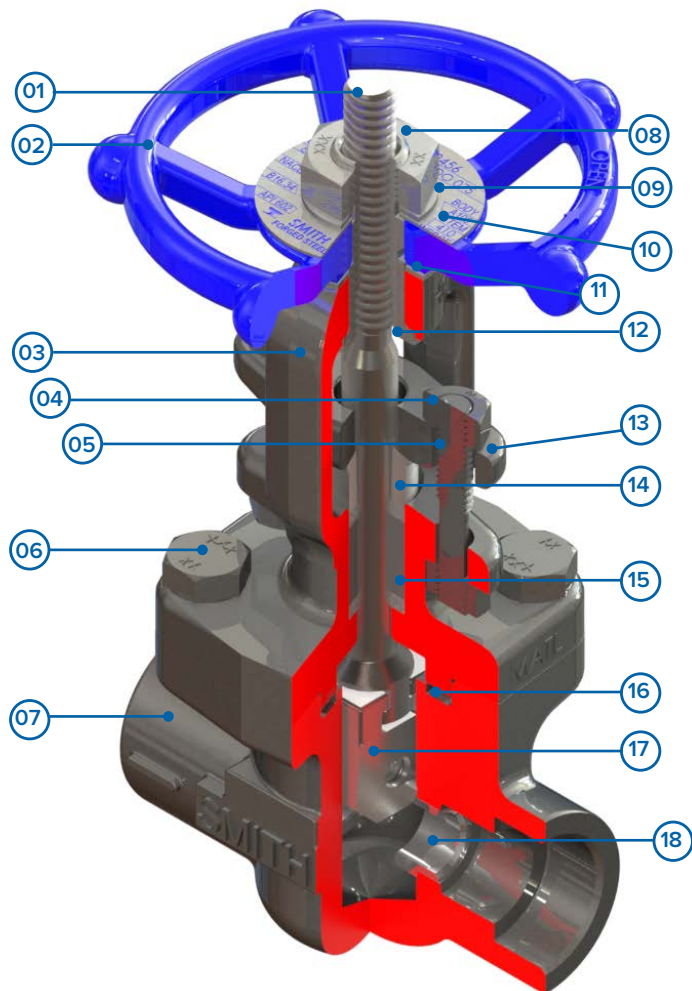



**0800  
0870**

## DIMENSIONAL DATA

Forged Gate OS&Y - Conventional Port

Sizes: 1/4" - 2"

Pressure Class: 800

End Connections - Threaded, Socketweld or Buttweld

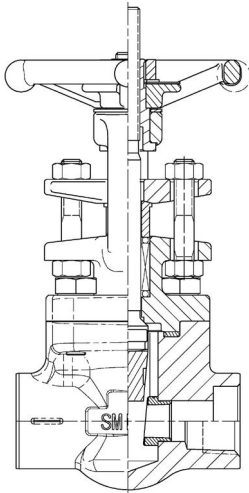

0800

**CLASS 800 BOLTED BONNET GATE VALVE  
THREADED or SOCKETWELD ENDS (IN.)**

VALVE SIZE NPS (DN)	END TO END	CENTER TO TOP (OPEN)	HANDWHEEL DIAMETER	APPROX. WEIGHT LBS
1/4	3.25	6.31	4.00	3.8
3/8	3.25	6.31	4.00	3.8
1/2	3.25	6.31	4.00	3.8
3/4	3.50	6.50	4.00	4.5
1	3.88	7.25	4.00	6.3
1 1/4	4.75	9.13	5.50	12.0
1 1/2	4.75	9.13	5.50	12.0
2	5.50	11.06	6.63	20.5

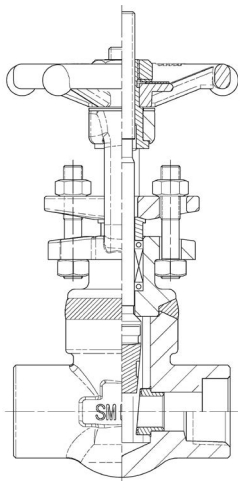

0870

**CLASS 800 WELDED BONNET GATE VALVE  
THREADED or SOCKETWELD ENDS (IN.)**

VALVE SIZE NPS (DN)	END TO END	CENTER TO TOP (OPEN)	HANDWHEEL DIAMETER	APPROX. WEIGHT LBS
1/4	3.25	6.19	4.00	3.3
3/8	3.25	6.25	4.00	3.3
1/2	3.25	6.25	4.00	3.3
3/4	3.50	6.50	4.00	3.8
1	3.88	7.25	4.00	5.3
1 1/4	4.75	9.13	5.50	10.3
1 1/2	4.75	9.13	5.50	9.8
2	5.50	11.00	6.63	16.0

**0888  
5870**

## DIMENSIONAL DATA

Forged Gate OS&Y - Full Port

Sizes: 1/4" - 2"

Pressure Class: 800

End Connections - Threaded or Socketweld

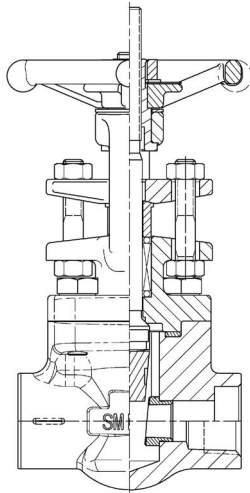

0888

**CLASS 800 BOLTED BONNET GATE VALVE  
THREADED or SOCKETWELD ENDS (IN.)**

VALVE SIZE NPS (DIN)	END TO END	CENTER TO TOP (OPEN)	HAND- WHEEL DIAMETER	APPROX. WEIGHT LBS
1/4	3.25	6.25	4.00	3.8
3/8	3.25	6.31	4.00	3.8
1/2	3.50	6.50	4.00	4.8
3/4	3.88	7.25	4.00	6.3
1	4.75	9.13	4.00	9.8
1 1/4	4.75	9.13	5.50	11.5
1 1/2	5.50	11.06	6.63	21.8
2	5.69	12.38	6.63	24.0

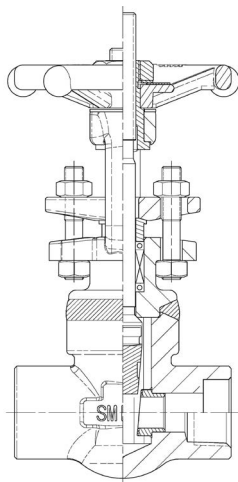

5870

**CLASS 800 WELDED BONNET GATE VALVE  
THREADED or SOCKETWELD (IN.)**

VALVE SIZE NPS (DIN)	END TO END	CENTER TO TOP (OPEN)	HAND- WHEEL DIAMETER	APPROX. WEIGHT LBS
1/4	3.25	6.25	4.00	3.3
3/8	3.25	6.25	4.00	3.3
1/2	3.50	6.50	4.00	4.3
3/4	3.94	7.25	4.00	5.8
1	4.75	8.94	5.50	10.5
1 1/4	4.75	9.13	5.50	10.3
1 1/2	5.50	11.00	6.63	17.0

**1500  
1570**

## DIMENSIONAL DATA

Forged Gate OS&Y - Conventional Port

Sizes: 1/4" - 2"

Pressure Class: 1500

End Connections - Threaded, Socketweld or Buttweld

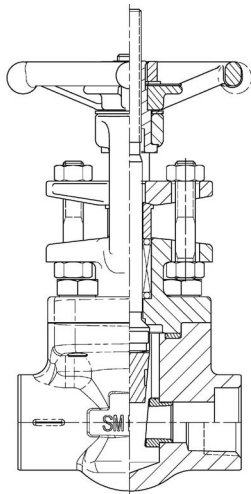

1500

CLASS 1500 BOLTED BONNET GATE VALVE THREADED or SOCKETWELD ENDS (IN.)				
VALVE SIZE NPS (DIN)	END TO END	CENTER TO TOP (OPEN)	HAND- WHEEL DIAMETER	APPROX. WEIGHT LBS
1/4	3.50	6.50	4.00	5.3
3/8	3.50	6.50	4.00	5.3
1/2	3.50	6.50	4.00	5.0
3/4	3.88	7.25	4.00	7.3
1	4.75	8.94	5.50	14.0
1 1/4	5.50	11.00	6.63	23.0
1 1/2	5.50	11.00	6.63	22.5
2	6.25	11.56	6.63	29.5

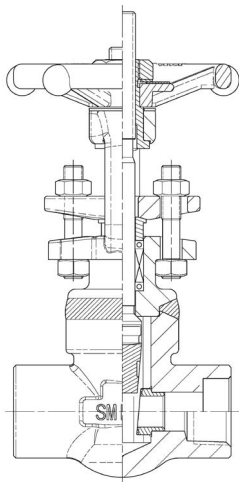

1570

CLASS 1500 WELDED BONNET GATE VALVE THREADED or SOCKETWELD ENDS (IN.)				
VALVE SIZE NPS (DIN)	END TO END	CENTER TO TOP (OPEN)	HAND- WHEEL DIAMETER	APPROX. WEIGHT LBS
1/4	3.50	6.31	4.00	4.8
3/8	3.50	6.38	4.00	4.8
1/2	3.50	6.38	4.00	4.5
3/4	3.88	7.00	4.00	6.0
1	4.75	8.75	5.50	11.3
1 1/4	5.50	10.69	6.63	17.8
1 1/2	5.50	10.69	6.63	17.5
2	6.25	11.06	6.63	24.2

**1588**  
**1578**

## DIMENSIONAL DATA

Forged Gate OS&Y - Full Port

Sizes: 1/4" - 1 1/2"

Pressure Class: 1500

End Connections - Threaded or Socketweld

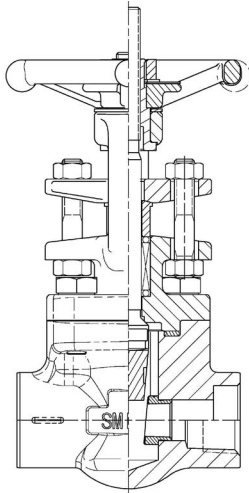

1588

CLASS 1500 BOLTED BONNET GATE VALVE THREADED or SOCKETWELD ENDS (IN.)				
VALVE SIZE NPS (DN)	END TO END	CENTER TO TOP (OPEN)	HAND- WHEEL DIAMETER	APPROX. WEIGHT LBS
1/4	3.50	6.44	4.00	5.3
3/8	3.50	6.50	4.00	5.3
1/2	3.94	6.88	4.00	7.5
3/4	4.75	8.94	4.00	14.8
1	4.75	9.06	5.50	23.5
1 1/4	5.50	11.00	6.63	23.0
1 1/2	6.25	11.56	6.63	30.5

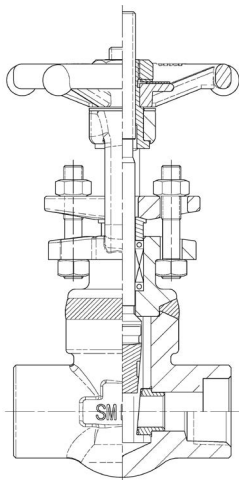

1578

CLASS 1500 WELDED BONNET GATE VALVE THREADED or SOCKETWELD ENDS (IN.)				
VALVE SIZE NPS (DN)	END TO END	CENTER TO TOP (OPEN)	HAND- WHEEL DIAMETER	APPROX. WEIGHT LBS
1/4	3.50	6.31	4.00	4.8
3/8	3.50	6.38	4.00	4.8
1/2	3.88	7.00	4.00	6.3
3/4	4.75	8.75	4.00	11.5
1	4.75	8.94	5.50	19.0
1 1/4	5.50	10.69	6.63	17.8
1 1/2	6.25	11.06	6.63	25.0

2578

## DIMENSIONAL DATA

Forged Gate OS&Y - Full Port

Sizes: 1/4" - 2"

Pressure Class: 2500

End Connections - Threaded or Socketweld

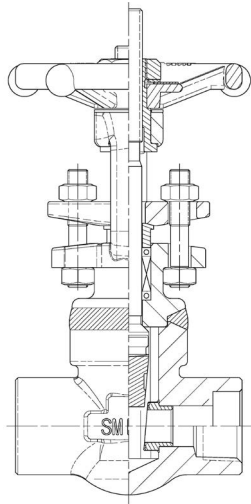

2578

CLASS 2500 WELDED BONNET GATE VALVE  
THREADED or SOCKETWELD ENDS (IN.)

VALVE SIZE NPS (DN)	END TO END	CENTER TO TOP (OPEN)	HAND- WHEEL DIAMETER	APPROX. WEIGHT LBS
1/2	3.88	7.26	4.00	6.3
3/4	4.65	9.05	5.50	11.3
1	5.40	9.44	5.50	17.8
1 1/2	6.15	12.06	6.63	18.5
2	6.15	12.06	6.63	18.5

**0815**  
**0830**  
**0860**

## DIMENSIONAL DATA

Forged Gate OS&Y - Conventional Port

Sizes: 1/2" - 3"

Pressure Class: 150 / 300 / 600

End Connections - Flanged

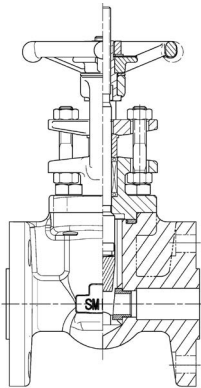

0815

CLASS 150 BOLTED BONNET GATE VALVE FLANGED ENDS (IN.)				
VALVE SIZE NPS (DIN)	END TO END	CENTER TO TOP (OPEN)	HANDWHEEL DIAMETER	APPROX. WEIGHT LBS
1/2	4.25	7.00	4.00	6.5
3/4	4.63	7.06	4.00	9.0
1	5.00	7.69	4.00	9.8
1 1/2	6.50	9.13	5.50	18.2
2	7.00	11.06	6.63	33.5
3	8.00	13.69	7.38	54.0

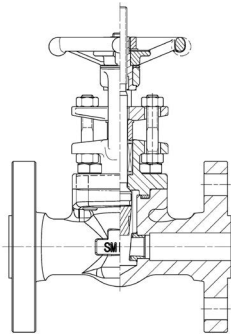

0830

CLASS 300 BOLTED BONNET GATE VALVE FLANGED ENDS (IN.)				
VALVE SIZE NPS (DIN)	END TO END	CENTER TO TOP (OPEN)	HANDWHEEL DIAMETER	APPROX. WEIGHT LBS
1/2	5.50	6.25	4.00	7.0
3/4	6.00	6.38	4.00	10.3
1	6.50	7.25	4.00	12.8
1 1/2	7.50	9.13	5.50	25.0
2	8.50	11.06	6.63	35.5
3	11.13	13.63	7.38	64.5

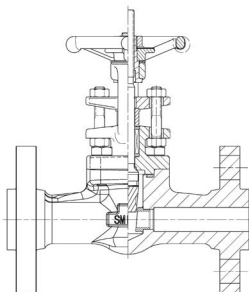

0860

CLASS 600 BOLTED BONNET GATE VALVE FLANGED ENDS (IN.)				
VALVE SIZE NPS (DIN)	END TO END	CENTER TO TOP (OPEN)	HANDWHEEL DIAMETER	APPROX. WEIGHT LBS
1/2	6.50	6.25	4.00	7.5
3/4	7.50	6.44	4.00	11.8
1	8.50	7.25	4.00	15.0
1 1/2	9.50	9.13	5.50	31.0
2	11.50	11.06	6.63	44.2

**5815  
5830**

## DIMENSIONAL DATA

Forged Gate OS&Y - Full Port

Sizes: 3/4" - 1 1/2"

Pressure Class: 150 & 300

End Connections - Flanged

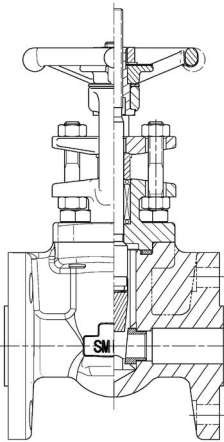

5815

CLASS 150 BOLTED BONNET GATE VALVE FLANGED ENDS (IN.)				
VALVE SIZE NPS (DIN)	END TO END	CENTER TO TOP (OPEN)	HANDWHEEL DIAMETER	APPROX. WEIGHT LBS
3/4	4.63	7.63	4.00	9.1
1	5.00	8.87	4.00	14.2
1 1/2	6.50	11.01	5.50	26.8

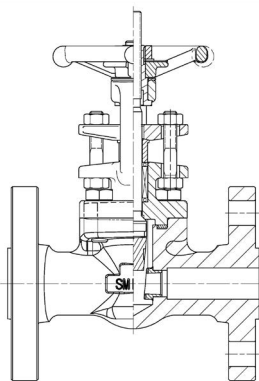

5830

CLASS 300 BOLTED BONNET GATE VALVE FLANGED ENDS (IN.)				
VALVE SIZE NPS (DIN)	END TO END	CENTER TO TOP (OPEN)	HANDWHEEL DIAMETER	APPROX. WEIGHT LBS
3/4	6.00	7.28	4.00	11.6
1	6.50	9.14	4.00	19.5
1 1/2	7.50	11.04	5.50	30.4

**0895  
2595**

## DIMENSIONAL DATA

Forged Gate OS&Y - Full Port  
 Sizes: 1/2" - 2"  
 Pressure Class: 1500 / 2500  
 End Connections - Flanged

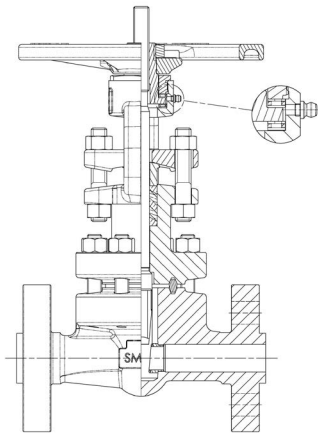

0895

CLASS 1500 BOLTED BONNET GATE VALVE FLANGED ENDS (IN.)				
VALVE SIZE NPS (DN)	END TO END	CENTER TO TOP (OPEN)	HANDWHEEL DIAMETER	APPROX. WEIGHT LBS
1/2	8.50	8.18	4.00	17.0
3/4	9.00	9.47	5.50	23.0
1	10.00	9.93	5.50	34.0
1 1/2	12.00	12.82	6.63	54.0
2	14.50	13.46	6.63	97.0

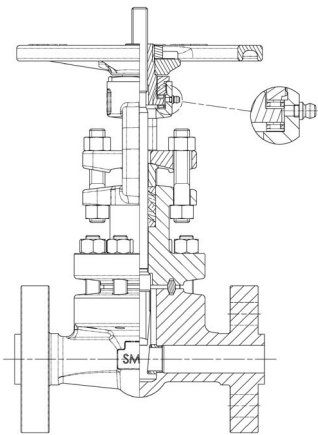

2595

CLASS 2500 BOLTED BONNET GATE VALVE FLANGED ENDS (IN.)				
VALVE SIZE NPS (DN)	END TO END	CENTER TO TOP (OPEN)	HANDWHEEL DIAMETER	APPROX. WEIGHT LBS
1/2	10.39	13.61	9.84	52.8
3/4	10.75	13.89	9.84	41.0
1	12.13	15.71	9.84	88.4
1 1/2	15.12	21.23	15.75	197.7
2	17.88	22.95	19.68	272.7



# EXTENDED BODY GATE VALVES

TAKEOFF & INTEGRAL REINFORCED EXTENDED BODY (IREB) VALVE



## DESIGN & CONSTRUCTION

- API 602, ASME B16.34
- Bolted & welded bonnet
- Reduced port
- Take-off design and IREB class 800
- Bonnet constructed of forged steel with integral backseat
- Nameplate serialized for full traceability
- API 622 and API 624 qualified packing for low emissions

- 01 STEM
- 02 HANDWHEEL
- 03 BONNET
- 04 GLAND STUD NUT
- 05 GLAND STUD
- 06 BONNET BOLT
- 07 BODY
- 08 HANDWHEEL NUT
- 09 LOCK WASHER
- 10 NAMEPLATE
- 11 THRUST WASHER
- 12 YOKE NUT
- 13 GLAND FLANGE
- 14 GLAND
- 15 PACKING
- 16 GASKET
- 17 WEDGE
- 18 SEAT RING

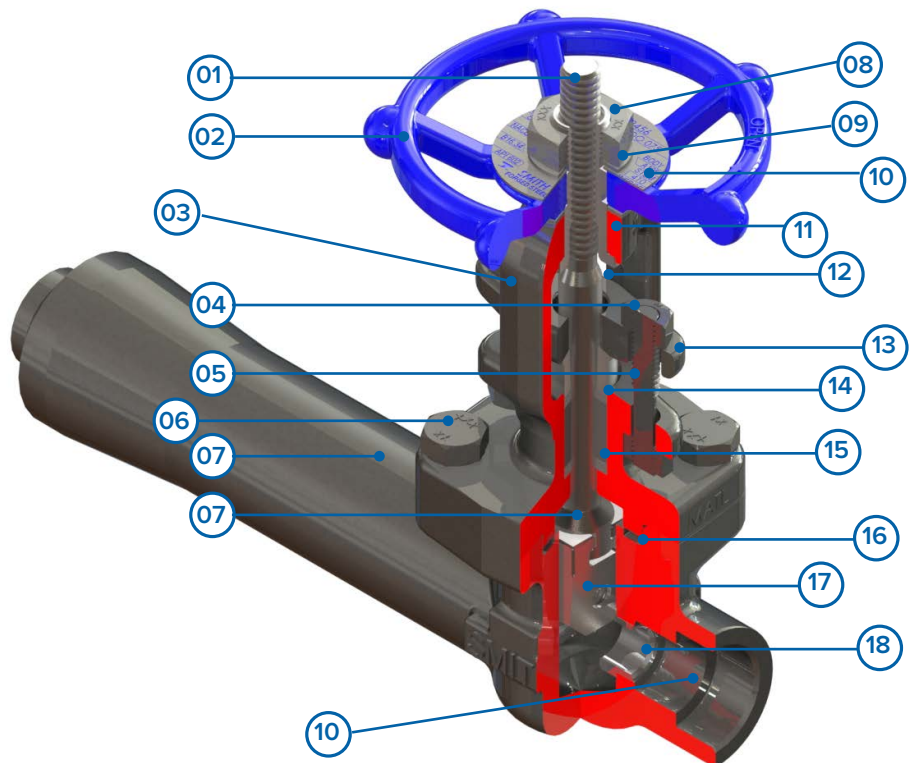

**0811-0814**  
**0876-0879**

## DIMENSIONAL DATA

Forged Gate OS&Y Male End  
Port: Conventional  
Sizes: 1/2" - 2"  
Pressure Class: 800

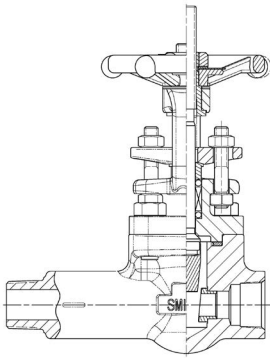

0811 Male Thread x Female Thread  
0812 Male Plain x Female Thread  
0813 Male Thread x Female S/W  
0814 Male Plain x Female S/W

CLASS 800 BOLTED BONNET GATE TAKE OFF DESIGN (IN.)					
VALVE SIZE NPS (DIN)	END TO END	CENTER TO TOP (OPEN)	HANDWHEEL DIAMETER	CENTER TO END	APPROX. WEIGHT LBS
1/2	5.63	6.25	4.00	4.00	4.3
3/4	5.75	6.50	4.00	4.00	5.0
1	5.94	7.25	4.00	4.00	6.8
1 1/2	7.38	9.13	5.50	5.00	10.2
2	7.88	11.06	6.63	5.13	12.8

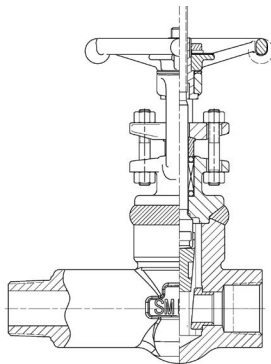

0876 Male Thread x Female Thread  
0877 Male Plain x Female Thread  
0878 Male Thread x Female S/W  
0879 Male Plain x Female S/W

CLASS 800 WELDED BONNET GATE TAKE OFF DESIGN (IN.)					
VALVE SIZE NPS (DIN)	END TO END	CENTER TO TOP (OPEN)	HANDWHEEL DIAMETER	CENTER TO END	APPROX. WEIGHT LBS
1/2	5.63	6.19	4.00	4.00	3.8
3/4	5.75	6.44	4.00	4.00	4.2
1	5.94	7.19	4.00	4.00	5.8
1 1/2	7.38	9.13	5.50	5.00	10.5
2	7.88	11.00	6.63	5.13	17.0

**0874**  
**0875**

## DIMENSIONAL DATA

Forged Gate OS&Y Integrally Reinforced Extended Body

Port: Conventional

Sizes: 1/2" - 2"

Pressure Class: 800

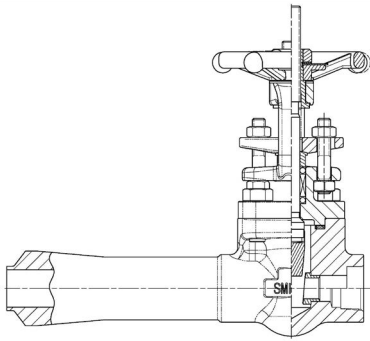

0874

### CLASS 800 BOLTED BONNET INTEGRALLY REINFORCED EXTENDED BODY GATE VALVE (IN.)

VALVE SIZE NPS (DN)	END TO END	CENTER TO TOP (OPEN)	HAND-WHEEL DIAMETER	CENTER TO END	APPROX. WEIGHT LBS
1/2	7.75	6.00	4.00	6.13	5.5
3/4	8.63	6.44	4.00	6.88	7.0
1	9.56	7.25	4.00	7.63	10.5
1 1/2	10.38	9.13	5.50	8.00	16.5
2	12.00	11.06	6.63	9.25	27.4

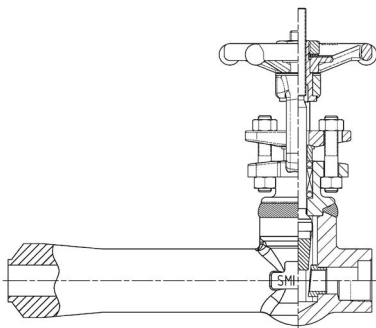

0875

### CLASS 800 WELDED BONNET INTEGRALLY REINFORCED EXTENDED BODY (IN.)

VALVE SIZE NPS (DN)	END TO END	CENTER TO TOP (OPEN)	HAND-WHEEL DIAMETER	CENTER TO END	APPROX. WEIGHT LBS
1/2	7.75	6.00	4.00	6.13	5.5
3/4	8.63	6.44	4.00	6.88	7.0
1	9.56	7.25	4.00	7.63	10.5
1 1/2	10.38	9.13	5.50	8.00	16.5
2	12.00	11.06	6.63	9.25	27.4

# BELLOWS SEAL GATE VALVES



## DESIGN & CONSTRUCTION

- API 602, ASME B16.34
- Bolted & welded bonnet
- Reduced and full port
- Threaded, Socketweld, Flanged ends class 150-600, 800 & 1500
- Bonnet constructed of forged steel with integral backseat
- Nameplate serialized for full traceability
- API 622 and API 624 qualified packing for low emissions

- 01 STEM
- 02 HANDWHEEL
- 03 BONNET
- 04 GLAND STUD NUT
- 05 GLAND STUD
- 06 EXTENSION TUBE
- 07 BODY
- 08 HANDWHEEL NUT
- 09 LOCK WASHER
- 10 NAMEPLATE
- 11 THRUST WASHER
- 12 YOKE NUT
- 13 GLAND FLANGE
- 14 GLAND
- 15 PACKING
- 16 BELLOWS COLLAR
- 17 BELLOWS
- 18 BONNET BOLT
- 19 WEDGE
- 20 SEAT RING

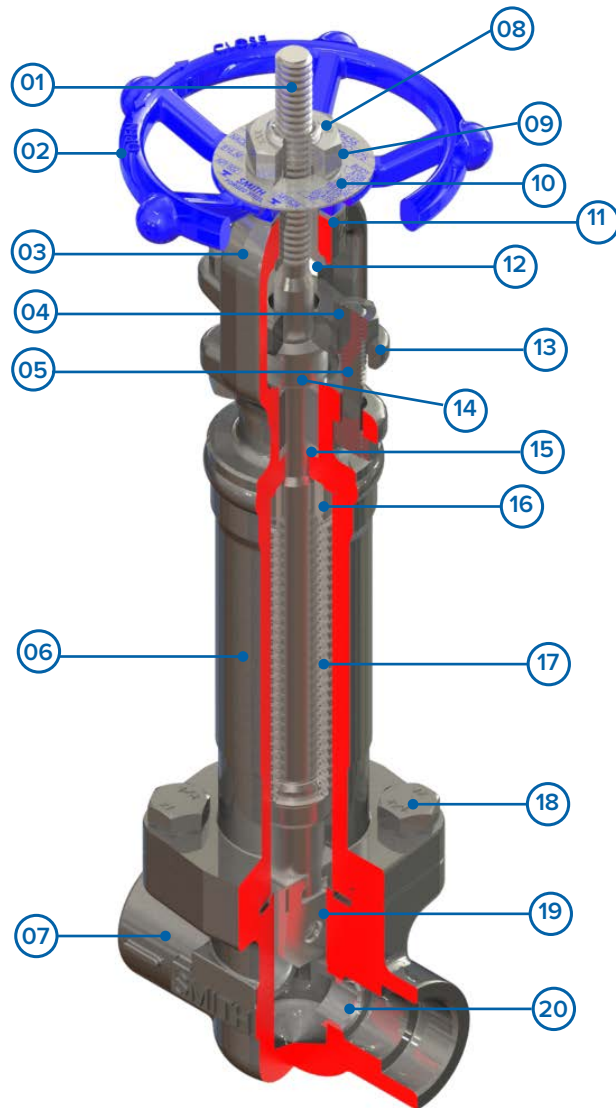

**B800  
B870**

## DIMENSIONAL DATA

Forged Gate OS&Y Conventional Port

Sizes: 1/2" - 2"

Pressure Class: 800

End Connections - Threaded or Socketweld

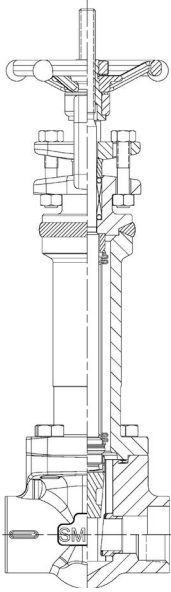

B800

CLASS 800 BOLTED BONNET BELLOWS GATE THREADED or SOCKETWELD ENDS (IN.)					
VALVE SIZE NPS (DN)	END TO END	CENTER TO TOP (OPEN)	HAND- WHEEL DIAMETER	THREADED END	APPROX. WEIGHT LBS
1/2	3.25	11.37	4.00	1/2"-14	6.8
3/4	3.50	11.37	4.00	3/4"-14	6.7
1	3.88	12.43	4.00	1"-11 1/2	8.4
1 1/2	4.75	17.30	5.50	1 1/2"-11 1/2	16.4
2	5.50	20.43	6.63	2"-11 1/2	28.6

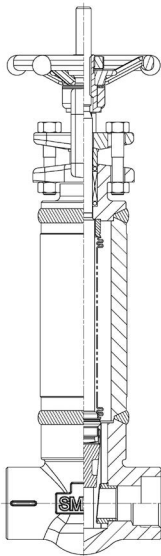

B870

CLASS 800 WELDED BONNET BELLOWS GATE THREADED or SOCKETWELD ENDS (IN.)					
VALVE SIZE NPS (DN)	END TO END	CENTER TO TOP (OPEN)	HAND- WHEEL DIAMETER	THREADED END	APPROX. WEIGHT LBS
1/2	3.25	10.41	4.00	1/2"-14	6.8
3/4	3.50	11.38	4.00	3/4"-14	6.7
1	3.88	12.43	4.00	1"-11 1/2	8.4
1 1/2	4.75	17.30	5.50	1 1/2"-11 1/2	16.4
2	5.50	20.40	6.63	2"-11 1/2	28.6

# B888

## DIMENSIONAL DATA

Forged Gate OS&Y - Full Port  
 Sizes: 1/4" - 2"  
 Pressure Class: 800  
 End Connections - Threaded or Socketweld

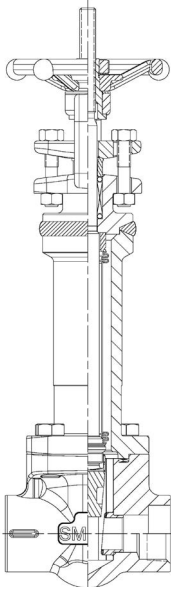

B888

CLASS 800 BOLTED BONNET GATE VALVE THREADED or SOCKETWELD (IN.)				
VALVE SIZE NPS (DN)	END TO END	CENTER TO TOP (OPEN)	HAND- WHEEL DIAMETER	APPROX. WEIGHT LBS
1/4	3.25	6.25	4.00	3.8
3/8	3.25	6.31	4.00	3.8
1/2	3.50	6.50	4.00	4.8
3/4	3.88	7.25	4.00	6.3
1	4.75	9.13	4.00	9.8
1 1/4	4.75	9.13	5.50	11.5
1 1/2	5.50	11.06	6.63	21.8
2	5.69	12.38	6.63	24.0

**B815  
B830  
B860**

## DIMENSIONAL DATA

Forged Gate OS&Y Conventional Port

Sizes: 1/2" - 2"

Pressure Class: 150 / 300 / 600

End Connections - Flanged

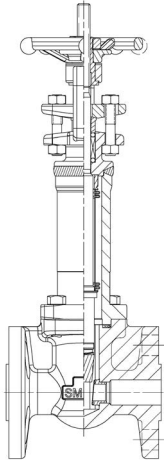

B815

### CLASS 150 BOLTED BONNET BELLOWS GATE FLANGED ENDS (IN.)

VALVE SIZE NPS (DIN)	END TO END	CENTER TO TOP (OPEN)	HAND-WHEEL DIAMETER	APPROX. WEIGHT LBS
1/2	4.25	11.60	4.00	8.0
3/4	4.61	11.60	4.00	9.7
1	5.00	12.64	4.00	12.2
1 1/2	6.50	15.21	5.50	20.7
2	7.00	19.54	6.63	37.1

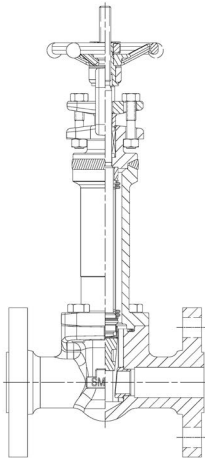

B830

### CLASS 300 BOLTED BONNET BELLOWS GATE FLANGED ENDS (IN.)

VALVE SIZE NPS (DIN)	END TO END	CENTER TO TOP (OPEN)	HAND-WHEEL DIAMETER	APPROX. WEIGHT LBS
1/2	6.00	11.29	4.00	11.9
3/4	6.50	12.42	4.00	14.9
1	7.50	17.31	5.50	28.8
1 1/2	8.50	20.40	6.63	42.7
2	5.50	20.40	6.63	28.6

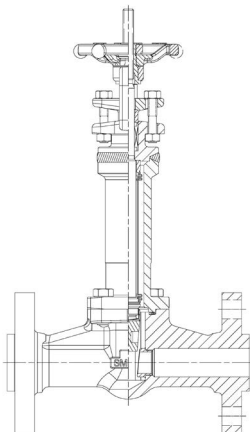

B860

### CLASS 600 BOLTED BONNET BELLOWS GATE FLANGED ENDS (IN.)

VALVE SIZE NPS (DIN)	END TO END	CENTER TO TOP (OPEN)	HAND-WHEEL DIAMETER	APPROX. WEIGHT LBS
1/2	7.48	11.37	4.00	12.9
3/4	8.50	12.43	4.00	17.1
1	9.49	17.30	5.50	34.7
1 1/2	11.50	20.40	6.63	52.0
2	5.50	20.40	6.63	28.6

**B817  
B837  
B867**

## DIMENSIONAL DATA

Forged Gate OS&Y - Conventional Port

Sizes: 1/2" - 2"

Pressure Class: 150 / 300 / 600

End Connections - Flanged

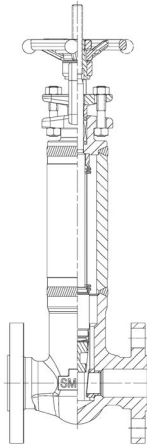

B817

### CLASS 150 WELDED BONNET BELLOWS GATE FLANGED ENDS (IN.)

VALVE SIZE NPS (DIN)	END TO END	CENTER TO TOP (OPEN)	HAND-WHEEL DIAMETER	APPROX. WEIGHT LBS
1/2	4.25	10.48	4.00	7.0
3/4	4.61	11.37	4.00	9.8
1	5.00	13.61	4.00	13.0
1 1/2	6.50	17.30	5.50	22.8
2	7.00	20.39	6.63	34.7

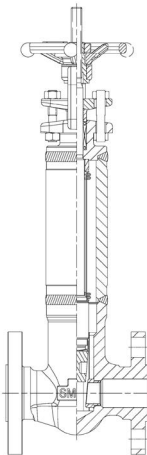

B837

### CLASS 300 WELDED BONNET BELLOWS GATE FLANGED ENDS (IN.)

VALVE SIZE NPS (DIN)	END TO END	CENTER TO TOP (OPEN)	HAND-WHEEL DIAMETER	APPROX. WEIGHT LBS
1/2	5.51	10.48	4.00	8.0
3/4	6.00	11.37	4.00	10.9
1	6.50	13.61	4.00	15.5
1 1/2	7.50	17.30	5.50	27.5
2	8.50	20.39	6.63	39.1

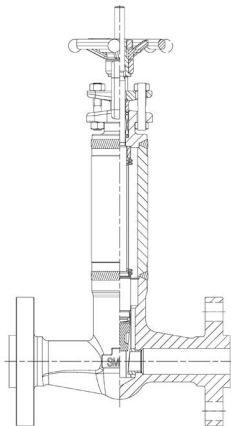

B867

### CLASS 600 WELDED BONNET BELLOWS GATE FLANGED ENDS (IN.)

VALVE SIZE NPS (DIN)	END TO END	CENTER TO TOP (OPEN)	HAND-WHEEL DIAMETER	APPROX. WEIGHT LBS
1/2	6.50	10.48	4.00	8.7
3/4	7.48	11.37	4.00	11.9
1	8.50	13.61	4.00	17.3
1 1/2	9.49	17.30	5.50	33.2
2	11.50	20.39	6.63	46.3



**B811-B814  
B876-B879**

## DIMENSIONAL DATA

Forged Gate OS&Y Male End  
 Port: Conventional  
 Sizes: 1/2" - 2"  
 Pressure Class: 800

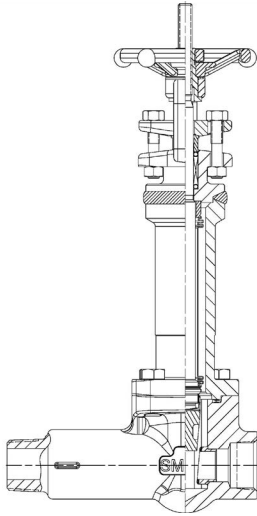

B811 Male Thread x Female Thread  
 B812 Male Plain x Female Thread  
 B813 Male Thread x Female S/W  
 B814 Male Plain x Female S/W

**CLASS 800 BOLTED BONNET BELLOWS GATE TAKE OFF DESIGN (IN.)**

VALVE SIZE NPS (DIN)	END TO END	CENTER TO TOP (OPEN)	HANDWHEEL DIAMETER	APPROX. WEIGHT LBS
1/2	5.63	10.39	4.00	6.75
3/4	5.75	11.38	4.00	6.45
1	5.94	12.67	4.00	7.85
1 1/2	7.38	17.26	5.50	14.9
2	7.87	19.33	6.63	25.1

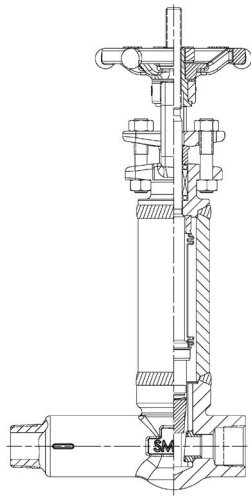

B876 Male Thread x Female Thread  
 B877 Male Plain x Female Thread  
 B878 Male Thread x Female S/W  
 B879 Male Plain x Female S/W

**CLASS 800 WELDED BONNET BELLOWS GATE TAKE OFF DESIGN (IN.)**

VALVE SIZE NPS (DIN)	END TO END	CENTER TO TOP (OPEN)	HANDWHEEL DIAMETER	APPROX. WEIGHT LBS
1/2	5.63	10.39	4.00	6.75
3/4	5.75	11.38	4.00	6.45
1	5.94	12.67	4.00	7.85
1 1/2	7.38	17.26	5.50	14.9
2	7.87	19.33	6.63	25.1

**B874  
B875**

## DIMENSIONAL DATA

Forged Gate OS&Y Integrally Reinforced Extended Body

Port: Conventional

Sizes: 1/2" - 2"

Pressure Class: 800

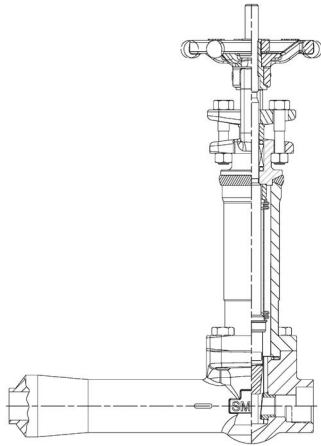

B874

CLASS 800 BOLTED BONNET IREB BELLOWS GATE THREADED or SOCKETWELD ENDS (IN.)				
VALVE SIZE NPS (DN)	END TO END	CENTER TO TOP (OPEN)	HANDWHEEL DIAMETER	APPROX. WEIGHT LBS
1/2	7.76	11.37	4.00	7.7
3/4	8.63	11.37	4.00	7.5
1	9.56	12.43	4.00	9.3
1 1/2	10.37	17.30	5.50	17.6
2	12.00	20.43	6.63	30.9

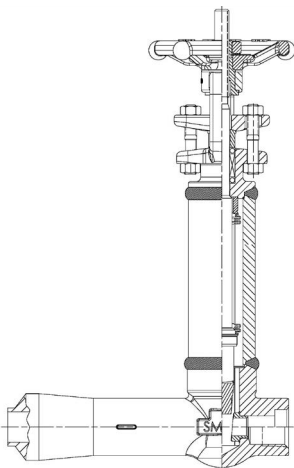

B875

CLASS 800 WELDED BONNET IREB BELLOWS GATE THREADED or SOCKETWELD ENDS (IN.)				
VALVE SIZE NPS (DN)	END TO END	CENTER TO TOP (OPEN)	HANDWHEEL DIAMETER	APPROX. WEIGHT LBS
1/2	7.76	11.37	4.00	7.7
3/4	8.63	11.37	4.00	7.5
1	9.56	12.43	4.00	9.3
1 1/2	10.37	17.30	5.50	17.6
2	12.00	20.43	6.63	30.9

# CRYOGENIC GATE VALVES



## DESIGN & CONSTRUCTION

- API 602, ASME B16.34, MSS SP-134
- Tested in accordance to API 598
- Bolted & welded bonnet
- Conventional port reduced and full port
- Threaded, Socketweld class 800
- Flanged ends class 150-800
- Bonnet constructed of forged steel with integral backseat
- Nameplate serialized for full traceability
- API 622 and API 624 qualified packing for low emissions
- Optional degrease, clean and seal to prevent contamination

- 01 HANDWHEEL
- 02 THRUST WASHER
- 03 GLAND STUD NUT
- 04 GLAND STUD
- 05 BONNET
- 06 EXTENSION TUBE
- 07 BONNET BOLT
- 08 BODY
- 09 HANDWHEEL NUT
- 10 LOCK WASHER
- 11 NAMEPLATE
- 12 YOKE NUT
- 13 GLAND FLANGE
- 14 GLAND
- 15 PACKING
- 16 STEM
- 17 GASKET
- 18 WEDGE
- 19 SEAT

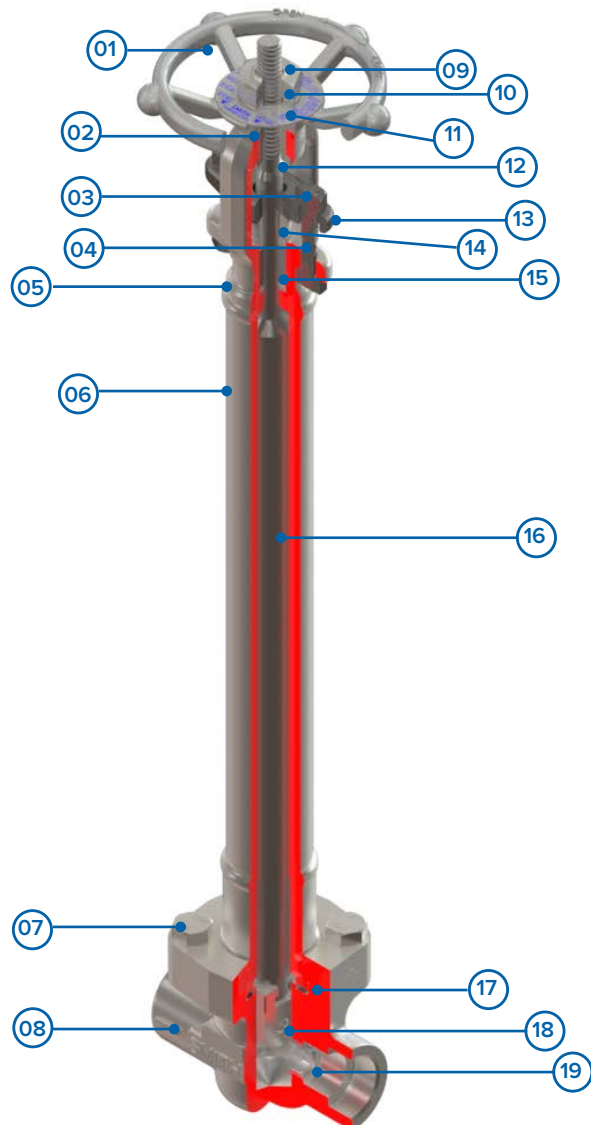

**C800  
C870**

## DIMENSIONAL DATA

Forged OS&Y - Conventional Port

Sizes: 1/2" - 2"

Pressure Class: 800

End Connections - Threaded or Socketweld

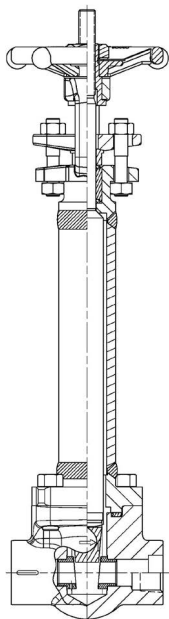

C800

CLASS 800 BOLTED BONNET CRYOGENIC GATE VALVE THREADED or SOCKETWELD ENDS (IN.)				
VALVE SIZE NPS (DIN)	END TO END	CENTER TO TOP (OPEN)	HANDWHEEL DIAMETER	APPROX. WEIGHT LBS
1/2	3.25	18.25	4.00	8.0
3/4	3.50	18.44	4.00	8.7
1	3.88	19.81	4.00	12.1
1 1/2	4.75	21.12	5.50	19.3
2	5.50	23.00	6.63	30.0

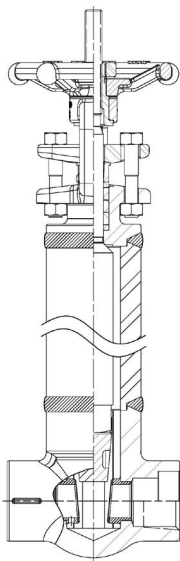

C870

CLASS 800 WELDED BONNET CRYOGENIC GATE VALVE THREADED or SOCKETWELD ENDS (IN.)				
VALVE SIZE NPS (DIN)	END TO END	CENTER TO TOP (OPEN)	HANDWHEEL DIAMETER	APPROX. WEIGHT LBS
1/2	3.25	18.25	4.00	10.6
3/4	3.50	18.50	4.00	11.8
1	3.88	19.19	4.00	15.6
1 1/2	4.75	21.19	5.50	22.2
2	5.50	23.12	6.63	32.2

**C815  
C830  
C860**

## DIMENSIONAL DATA

Forged OS&Y - Conventional Port

Sizes: 1/2" - 2"

Pressure Class: 150 / 300 / 600

End Connections - Flanged

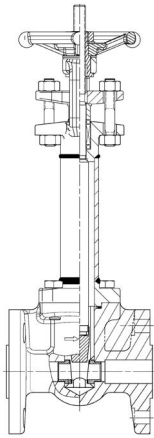

C815

### CLASS 150 BOLTED BONNET CRYOGENIC GATE VALVE FLANGED ENDS (IN.)

VALVE SIZE NPS (DIN)	FACE TO FACE	CENTER TO TOP (OPEN)	HANDWHEEL DIAMETER	APPROX. WEIGHT LBS
1/2	4.25	18.88	4.00	10.8
3/4	4.63	19.06	4.00	13.3
1	5.00	20.25	4.00	15.2
1 1/2	6.50	21.12	5.50	25.0
2	7.00	23.00	6.63	42.2

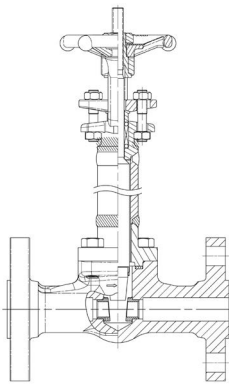

C830

### CLASS 300 BOLTED BONNET CRYOGENIC GATE VALVE FLANGED ENDS (IN.)

VALVE SIZE NPS (DIN)	FACE TO FACE	CENTER TO TOP (OPEN)	HANDWHEEL DIAMETER	APPROX. WEIGHT LBS
1/2	5.50	18.19	4.00	11.3
3/4	6.00	18.38	4.00	14.5
1	6.50	19.81	4.00	18.2
1 1/2	7.50	21.13	5.50	31.3
2	8.50	23.00	6.63	44.2

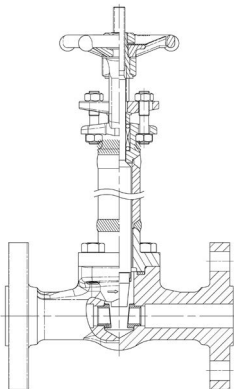

C860

### CLASS 600 BOLTED BONNET CRYOGENIC GATE VALVE FLANGED ENDS (IN.)

VALVE SIZE NPS (DIN)	FACE TO FACE	CENTER TO TOP (OPEN)	HANDWHEEL DIAMETER	APPROX. WEIGHT LBS
1/2	6.50	18.19	4.00	11.8
3/4	7.50	18.38	4.00	16.0
1	8.50	19.81	4.00	20.5
1 1/2	9.50	21.12	5.50	37.2
2	11.50	23.00	6.63	53.9

# GLOBE VALVES



## DESIGN & CONSTRUCTION

- API 602, ASME B16.34
- Bolted & welded bonnet
- Reduced and full port
- Threaded, Socketweld, Buttweld, ends class 800 to 1500
- Flanged ends class 150 - 2500
- Bonnet constructed of forged steel with integral backseat
- Nameplate serialized for full traceability
- API 622 and API 624 qualified packing for low emissions
- Forged arrow on the body indicates flow direction

- 01 HANDWHEEL
- 02 STEM
- 03 BONNET
- 04 GLAND NUT STUD
- 05 GLAND STUD
- 06 BONNET BOLT
- 07 BODY
- 08 HANDWHEEL NUT
- 09 NAMEPLATE
- 10 YOKE NUT
- 11 GLAND FLANGE
- 12 GLAND
- 13 PACKING
- 14 GASKET
- 15 DISC
- 16 SEAT

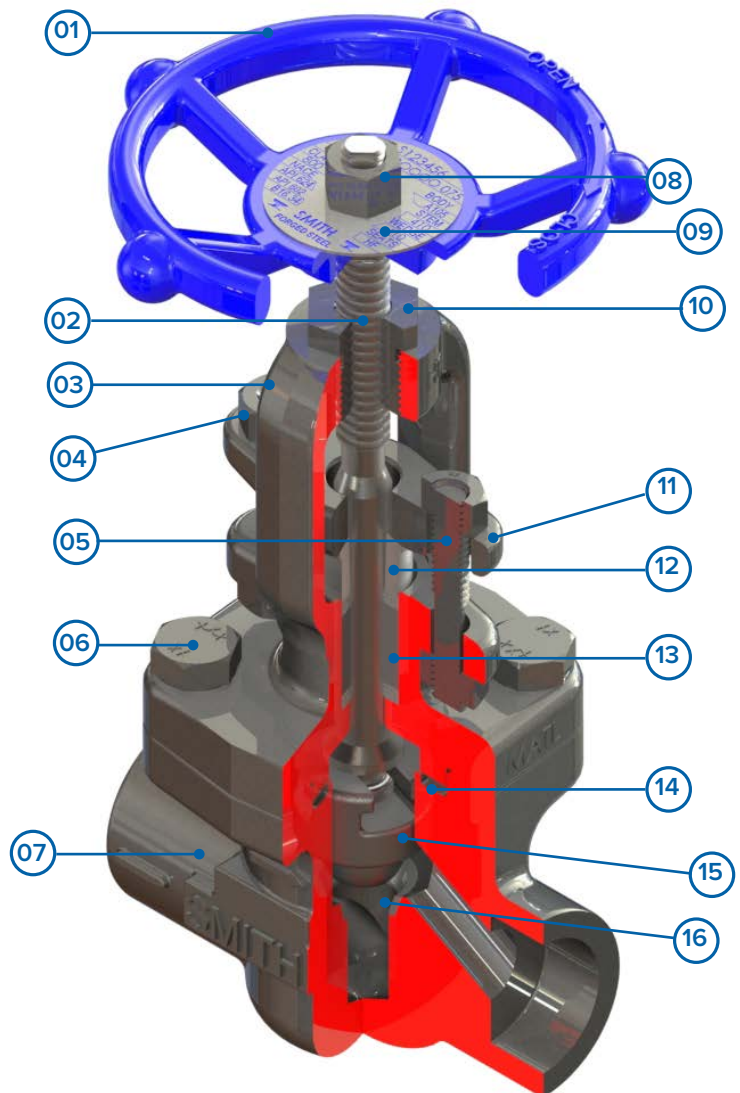

Needle Globe Option

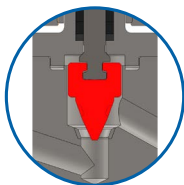

**OG80  
OG87**

## DIMENSIONAL DATA

Forged Globe OS&Y - Conventional Port  
Sizes: 1/4" - 2"

Pressure Class: 800

End Connections - Threaded or Socketweld

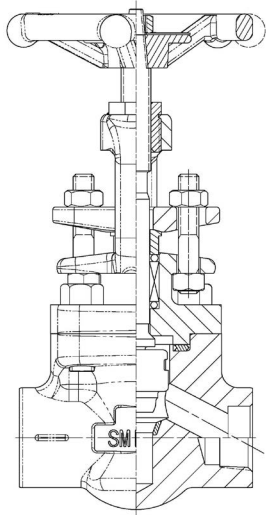

OG80

**CLASS 800 BOLTED BONNET GLOBE VALVE  
THREADED or SOCKETWELD ENDS (IN.)**

VALVE SIZE NPS (DIN)	END TO END	CENTER TO TOP (OPEN)	HANDWHEEL DIAMETER	APPROX. WEIGHT LBS
1/4	3.25	6.31	4.00	3.8
3/8	3.25	6.31	4.00	3.8
1/2	3.25	6.31	4.00	3.8
3/4	3.50	6.50	4.00	4.8
1	4.50	6.81	4.00	6.3
1 1/4	6.25	8.13	4.63	12.8
1 1/2	6.25	8.13	4.63	12.3
2	7.25	9.94	6.63	22.5

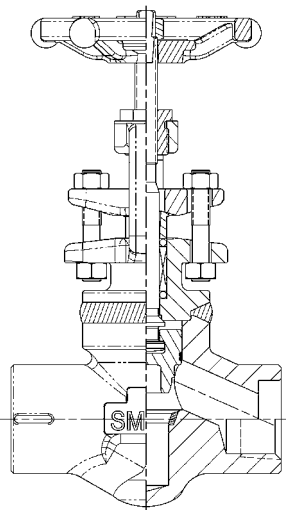

OG87

**CLASS 800 WELDED BONNET GLOBE VALVE  
THREADED or SOCKETWELD ENDS (IN.)**

VALVE SIZE NPS (DIN)	END TO END	CENTER TO TOP (OPEN)	HANDWHEEL DIAMETER	APPROX. WEIGHT LBS
1/4	3.25	6.38	4.00	3.5
3/8	3.25	6.38	4.00	3.5
1/2	3.25	6.38	4.00	3.5
3/4	3.50	6.50	4.00	4.5
1	4.50	6.81	4.00	6.0
1 1/4	6.25	8.19	4.63	12.3
1 1/2	6.25	8.19	4.63	11.8
2	7.25	10.00	6.63	22.0

# G150 G157

## DIMENSIONAL DATA

Forged Globe OS&Y - Conventional Port

Sizes: 1/4" - 2"

Pressure Class: 1500

End Connections - Threaded or Socketweld

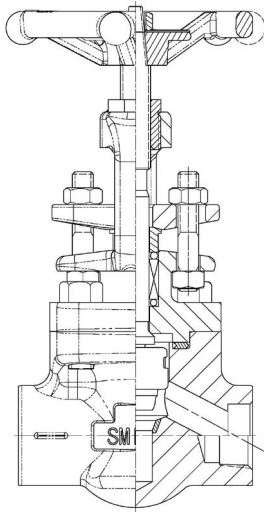

G150

### CLASS 1500 BOLTED BONNET GLOBE VALVE THREADED or SOCKETWELD ENDS (IN.)

VALVE SIZE NPS (DN)	END TO END	CENTER TO TOP (OPEN)	HANDWHEEL DIAMETER	APPROX. WEIGHT LBS
1/4	3.50	6.63	4.00	6.0
3/8	3.50	6.63	4.00	6.0
1/2	3.50	6.63	4.00	5.8
3/4	4.50	6.75	4.00	8.5
1	6.25	7.88	4.63	14.8
1 1/4	7.25	9.94	6.63	27.0
1 1/2	7.25	9.94	6.63	27.0
2	7.25	10.75	6.63	31.0

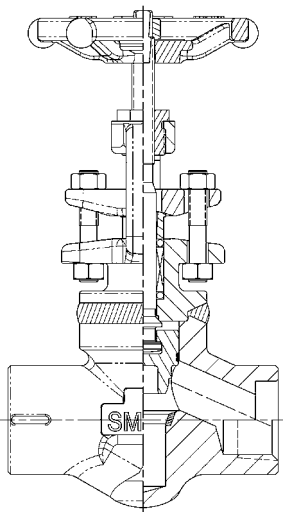

G157

### CLASS 1500 WELDED BONNET GLOBE VALVE THREADED or SOCKETWELD ENDS (IN.)

VALVE SIZE NPS (DN)	END TO END	CENTER TO TOP (OPEN)	HANDWHEEL DIAMETER	APPROX. WEIGHT LBS
1/4	3.50	6.56	4.00	4.3
3/8	3.50	6.56	4.00	4.3
1/2	3.50	6.56	4.00	4.0
3/4	4.50	6.88	4.00	6.0
1	6.25	8.19	4.63	12.5
1 1/4	7.25	10.31	6.63	19.5
1 1/2	7.25	10.31	6.63	19.5
2	7.25	10.38	6.63	24.0



**OG81  
OG83  
OG86**

## DIMENSIONAL DATA

Forged Globe OS&Y - Conventional Port

Sizes: 1/2" - 2"

Pressure Class: 150/300/600

End Connections - Flanged

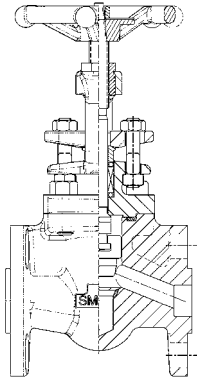

OG81

### CLASS 150 BOLTED BONNET GLOBE VALVE FLANGED ENDS (IN.)

VALVE SIZE NPS (DN)	FACE TO FACE	CENTER TO TOP (OPEN)	HANDWHEEL DIAMETER	APPROX. WEIGHT LBS
1/2	4.25	5.69	3.25	3.7
3/4	4.63	5.94	3.94	5.3
1	5.00	6.75	3.94	9.8
1 1/2	6.50	8.44	5.50	18.5
2	7.00	9.69	6.25	36.0

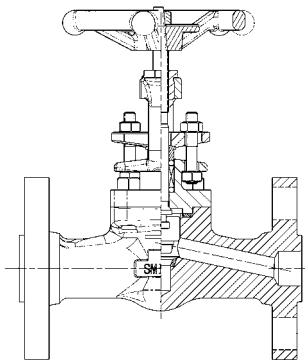

OG83

### CLASS 300 BOLTED BONNET GLOBE VALVE FLANGED ENDS (IN.)

VALVE SIZE NPS (DN)	FACE TO FACE	CENTER TO TOP (OPEN)	HANDWHEEL DIAMETER	APPROX. WEIGHT LBS
1/2	6.00	6.31	4.00	7.3
3/4	7.00	6.50	4.00	11.0
1	8.00	7.19	4.00	14.5
1 1/2	9.00	8.88	4.63	31.0
2	10.50	10.63	6.63	41.2

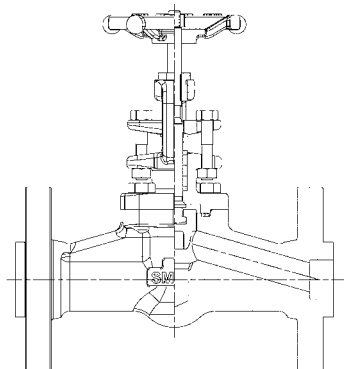

OG86

### CLASS 600 BOLTED BONNET GLOBE VALVE FLANGED ENDS (IN.)

VALVE SIZE NPS (DN)	FACE TO FACE	CENTER TO TOP (OPEN)	HANDWHEEL DIAMETER	APPROX. WEIGHT LBS
1/2	6.50	6.31	4.00	7.8
3/4	7.50	6.50	4.00	11.8
1	8.50	7.19	4.00	15.3
1 1/2	9.50	8.88	4.63	31.8
2	11.50	10.63	6.63	46.8

**G895  
G259**

## DIMENSIONAL DATA

Forged Globe OS&Y - Conventional Port

Sizes: 1/2" - 2"

Pressure Class: 1500 / 2500

End Connections - Flanged

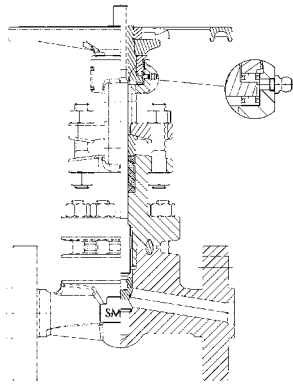

G895

CLASS 1500 BOLTED BONNET GLOBE VALVE FLANGED ENDS (IN.)				
VALVE SIZE NPS (DIN)	FACE TO FACE	CENTER TO TOP (OPEN)	HANDWHEEL DIAMETER	APPROX. WEIGHT LBS
1/2	8.50	7.98	4.00	3.25
3/4	9.00	8.69	5.50	3.50
1	10.00	10.00	5.50	4.00
1 1/2	12.00	11.89	6.63	4.88
2	14.50	12.98	6.63	6.50

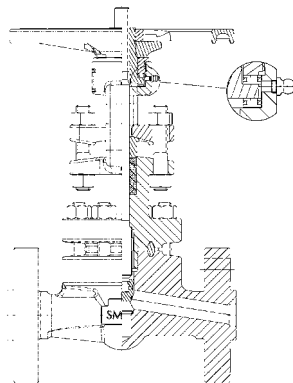

G259

CLASS 2500 BOLTED BONNET GLOBE VALVE FLANGED ENDS (IN.)				
VALVE SIZE NPS (DIN)	FACE TO FACE	CENTER TO TOP (OPEN)	HANDWHEEL DIAMETER	APPROX. WEIGHT LBS
1/2	10.39	13.22	9.84	53.6
3/4	10.75	13.23	9.84	55.8
1	12.13	15.36	9.84	92.1
1 1/2	15.12	20.54	15.75	202.7

# FG80 FG81

## DIMENSIONAL DATA

Forged Globe OS&Y - Conventional Port

Sizes: 1/2" - 1"

Pressure Class: 150 / 800

End Connections - Threaded, Socketweld or Flanged

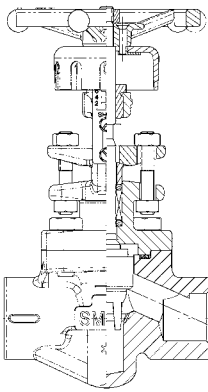

FG80

CLASS 800 BOLTED BONNET FLOW CONTROL GLOBE VALVE THREADED or SOCKETWELD ENDS (IN.)				
VALVE SIZE NPS (DIN)	END TO END	CENTER TO TOP (OPEN)	HANDWHEEL DIAMETER	APPROX. WEIGHT LBS
1/2	3.25	6.50	4.00	4.3
3/4	3.50	6.58	4.00	5.3
1	4.50	6.71	4.00	7.0

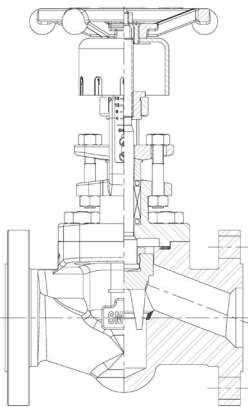

FG81

CLASS 150 BOLTED BONNET FLOW CONTROL GLOBE VALVE - FLANGED ENDS (IN.)				
VALVE SIZE NPS (DIN)	FACE TO FACE	CENTER TO TOP (OPEN)	HANDWHEEL DIAMETER	APPROX. WEIGHT LBS
1/2	4.25	5.69	3.25	3.7
3/4	4.63	5.94	3.94	5.3
1	5.00	6.75	3.94	9.8
1 1/2	6.50	8.44	5.50	18.5
2	7.00	9.69	6.25	36.0

# BELLOWS SEAL GLOBE VALVES



## DESIGN & CONSTRUCTION

- API 602, ASME B16.34
- Bolted & welded bonnet
- Reduced port
- Threaded, Socketweld or Flanged ends class 150-600, 800, 1500
- Zero emissions
- Full strength weld
- Bonnet constructed of forged steel with integral backseat
- Nameplate serialized for full traceability
- API 622 and API 624 qualified packing for low emissions

- 01 STEM
- 02 HANDWHEEL
- 03 BONNET
- 04 GLAND STUD NUT
- 05 GLAND STUD
- 06 EXTENSION TUBE
- 07 BODY
- 08 HANDWHEEL NUT
- 09 LOCK WASHER
- 10 NAMEPLATE
- 11 THRUST WASHER
- 12 YOKE NUT
- 13 GLAND FLANGE
- 14 GLAND
- 15 PACKING
- 16 COLLAR
- 17 KEY
- 18 BELLOWS
- 19 WEDGE
- 20 SEAT RING

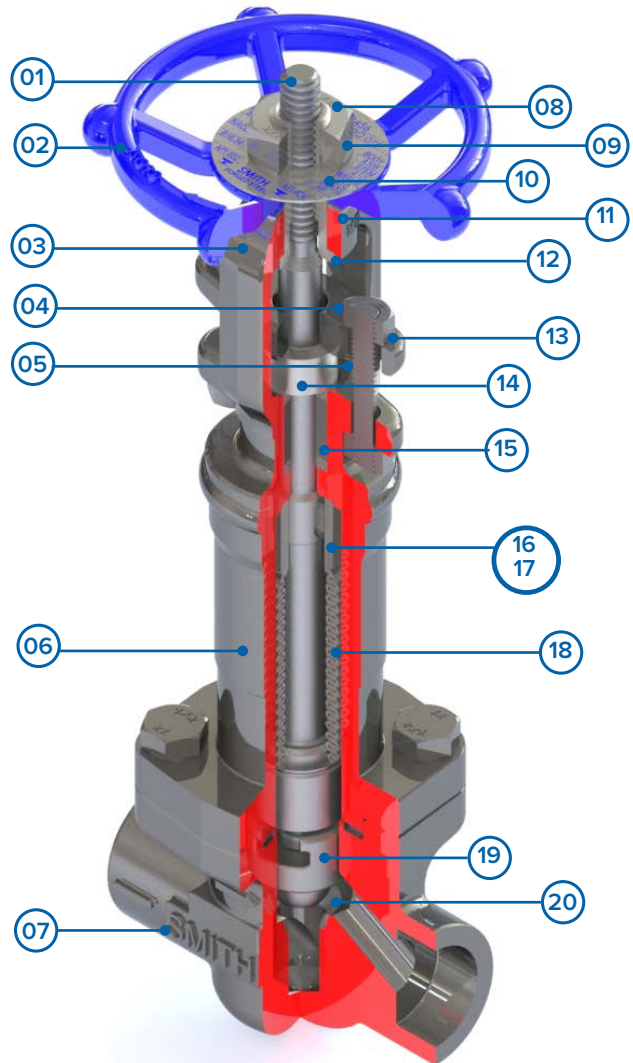

# BG80 BG87

## DIMENSIONAL DATA

Forged Globe OS&Y - Conventional Port

Sizes: 1/2" - 2"

Pressure Class: 800

End Connections - Threaded or Socketweld

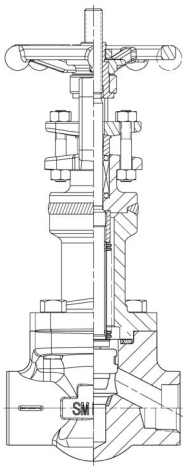

BG80

CLASS 800 BOLTED BONNET BELLOWS GLOBE VALVE THREADED or SOCKETWELD ENDS (IN.)				
VALVE SIZE NPS (DIN)	END TO END	CENTER TO TOP (OPEN)	HANDWHEEL DIAMETER	APPROX. WEIGHT LBS
1/2	3.25	9.53	4.00	6.4
3/4	3.50	9.53	4.00	6.4
1	4.50	9.44	4.00	8.6
1 1/2	6.25	11.13	4.63	14.7
2	7.25	13.56	6.63	29.2

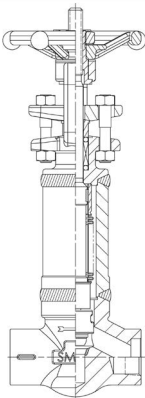

BG87

CLASS 800 WELDED BONNET BELLOWS GLOBE VALVE THREADED or SOCKETWELDS (IN.)				
VALVE SIZE NPS (DIN)	END TO END	CENTER TO TOP (OPEN)	HANDWHEEL DIAMETER	APPROX. WEIGHT LBS
1/2	3.25	9.27	4.00	4.5
3/4	3.50	9.35	4.00	5.1
1	4.50	9.45	4.00	6.9
1 1/2	6.25	10.77	4.63	15.1
2	7.25	13.89	6.63	19.3

# BG15 BG17

## DIMENSIONAL DATA

Forged Globe OS&Y - Conventional Port  
 Sizes: 1/2" - 2"  
 Pressure Class: 1500  
 End Connections - Threaded or Socketweld

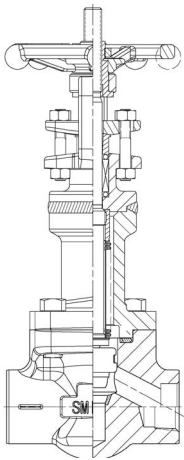

BG15

CLASS 1500 BOLTED BONNET BELLOWS GLOBE VALVE THREADED or SOCKETWELD ENDS (IN.)				
VALVE SIZE NPS (DN)	END TO END	CENTER TO TOP (OPEN)	HANDWHEEL DIAMETER	APPROX. WEIGHT LBS
1	6.25	10.93	5.50	18.5
2	7.25	13.56	6.63	34.9

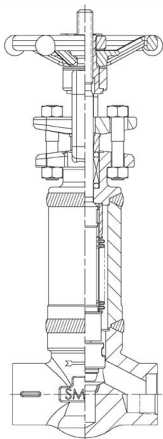

BG17

CLASS 1500 WELDED BONNET BELLOWS GLOBE VALVE THREADED or SOCKETWELD ENDS (IN.)				
VALVE SIZE NPS (DN)	END TO END	CENTER TO TOP (OPEN)	HANDWHEEL DIAMETER	APPROX. WEIGHT LBS
1/2	3.50	9.24	4.00	5.9
3/4	4.50	9.69	4.00	6.6

**BG81  
BG71  
BG83  
BG73**

## DIMENSIONAL DATA

Forged Globe OS&Y - Conventional Port

Sizes: 1/2" - 2"

Pressure Class: 150

End Connections - Flanged

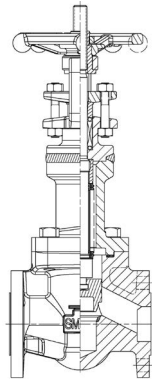

BG81

CLASS 150 BOLTED BONNET BELLOWS GLOBE VALVE FLANGED ENDS (IN.)				
VALVE SIZE NPS (DIN)	END TO END	CENTER TO TOP (OPEN)	HANDWHEEL DIAMETER	APPROX. WEIGHT LBS
1/2	4.25	10.18	4.00	9.2
3/4	4.61	10.24	4.00	12.1
1	5.00	11.91	5.50	18.0
1 1/2	6.50	12.77	6.63	32.8
2	8.00	13.56	6.63	36.6

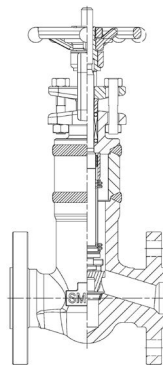

BG71

CLASS 150 WELDED BONNET BELLOWS GLOBE VALVE FLANGED ENDS (IN.)				
VALVE SIZE NPS (DIN)	END TO END	CENTER TO TOP (OPEN)	HANDWHEEL DIAMETER	APPROX. WEIGHT LBS
1/2	4.25	9.04	4.00	8.1
3/4	4.61	9.28	4.00	10.9
1	5.00	9.33	4.00	16.4
1 1/2	6.50	10.94	5.50	31.0
2	8.00	13.02	6.63	34.3

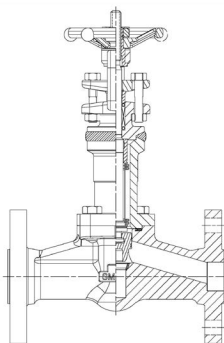

BG83

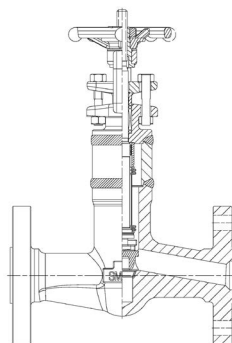

BG73

CLASS 300 BOLTED / WELDED BONNET BELLOWS GLOBE VALVE FLANGED ENDS (IN.)				
VALVE SIZE NPS (DIN)	END TO END	CENTER TO TOP (OPEN)	HANDWHEEL DIAMETER	APPROX. WEIGHT LBS
1/2	5.98	9.25	4.00	9.9
3/4	7.01	9.53	4.00	11.9
1	7.99	9.84	4.00	14.9
1 1/2	9.02	11.22	5.50	28.8
2	10.51	13.56	6.63	42.7

**BG86  
BG76  
BG89**

## DIMENSIONAL DATA

Forged Globe OS&Y - Conventional Port

Sizes: 1/2" - 1"

Pressure Class: 600 / 1500

End Connections - Flanged

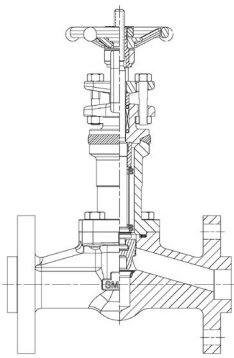

BG86

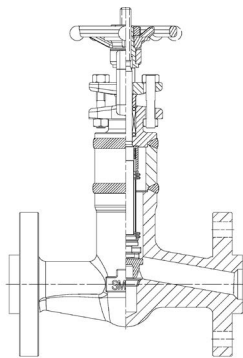

BG76

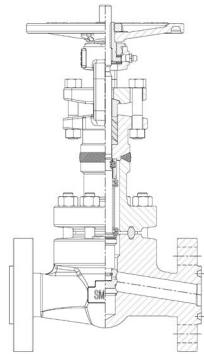

BG89

### CLASS 600 BOLTED / WELDED BONNET BELLOWS GLOBE VALVE FLANGED ENDS (IN.)

VALVE SIZE NPS (DN)	END TO END	CENTER TO TOP (OPEN)	HANDWHEEL DIAMETER	APPROX. WEIGHT LBS
1/2	6.50	10.43	4.00	10.8
3/4	7.48	11.37	4.00	12.9
1	8.50	12.43	4.00	17.1
1 1/2	9.50	17.30	5.50	34.7
2	11.50	20.40	6.63	52.0

### CLASS 1500 BOLTED BONNET BELLOWS GLOBE VALVE FLANGED ENDS (IN.)

VALVE SIZE NPS (DN)	END TO END	CENTER TO TOP (OPEN)	HANDWHEEL DIAMETER	APPROX. WEIGHT LBS
1 1/2	12.01	18.17	9.84	93.7



# BY15

## DIMENSIONAL DATA

Forged Globe OS&Y - Full Port  
Sizes: 1/2" - 1"  
Pressure Class: 1500  
End Connections - Buttweld

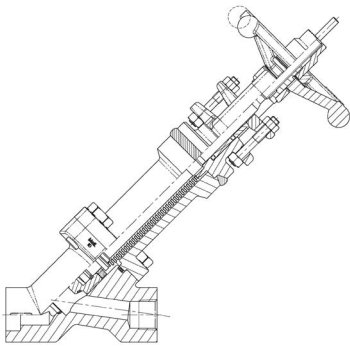

BY15

### CLASS 1500 BOLTED BONNET BELLOWS Y-PATTERN GLOBE VALVE BUTTWELD ENDS (IN.)

VALVE SIZE NPS (DN)	END TO END	CENTER TO TOP (OPEN)	HANDWHEEL DIAMETER	APPROX. WEIGHT LBS
1/2	4.72	7.87	4.00	7.2
3/4	5.12	10.31	5.50	11.2
1	7.17	14.21	6.63	27.5
1 1/2	7.68	13.93	6.63	35.9
2	7.68	13.72	6.63	35.1

# CRYOGENIC GLOBE VALVES



## DESIGN & CONSTRUCTION

- API 602, ASME B16.34, MSS SP-134
- Tested in accordance to API 598
- Bolted & welded bonnet
- Conventional port
- Threaded, Socketweld, Flanged ends class 150-600 & 800
- Bonnet constructed of forged steel with integral backseat
- Nameplate serialized for full traceability
- API 622 and API 624 qualified packing for low emissions
- Optional degrease, clean and seal to prevent contamination

- 01** HANDWHEEL
- 02** GLAND STUD NUT
- 03** GLAND STUD
- 04** BONNET
- 05** EXTENSION TUBE
- 06** BONNET BOLT
- 07** BODY
- 08** HANDWHEEL NUT
- 09** NAMEPLATE
- 10** YOKE NUT
- 11** GLAND FLANGE
- 12** GLAND
- 13** PACKING
- 14** STEM
- 15** GASKET
- 16** DISC
- 17** SEAT

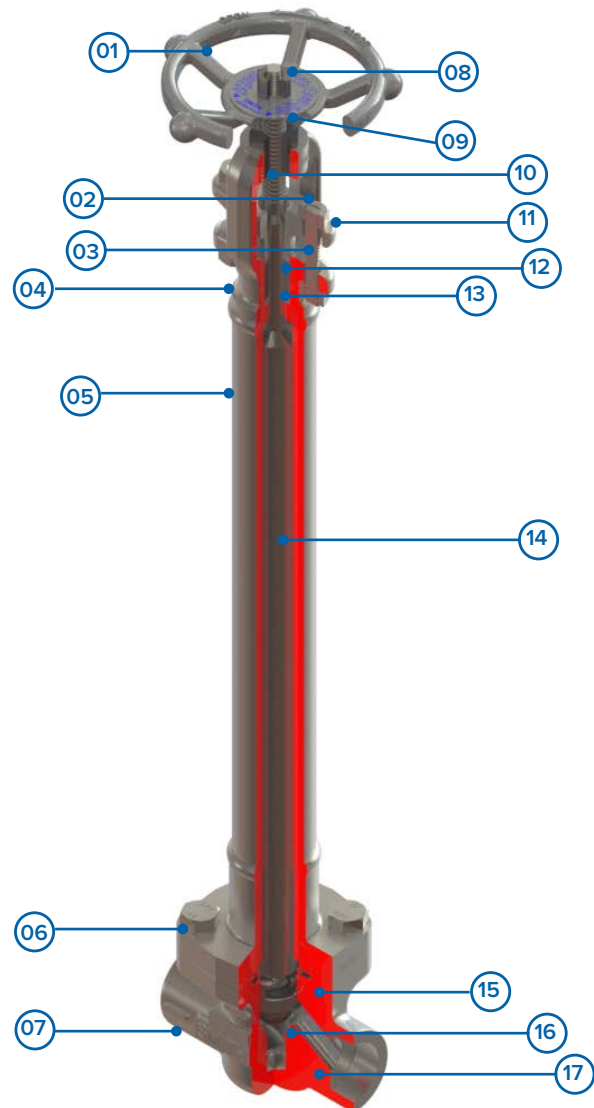

**CG80  
CG87**

## DIMENSIONAL DATA

Forged OS&Y - Conventional Port

Sizes: 1/2" - 2"

Pressure Class: 800

End Connections - Threaded or Socketweld

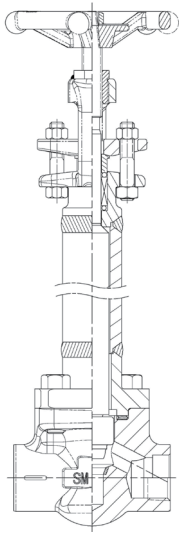

CG80

**CLASS 800 BOLTED BONNET CRYOGENIC GLOBE VALVE  
THREADED or SOCKETWELD ENDS (IN.)**

VALVE SIZE NPS (DIN)	END TO END	CENTER TO TOP (OPEN)	HANDWHEEL DIAMETER	APPROX. WEIGHT LBS
1/2	3.25	18.31	4.00	8.0
3/4	3.50	18.50	4.00	8.9
1	4.50	18.75	4.00	21.1
1 1/2	6.25	20.13	5.50	19.5
2	7.25	21.94	6.63	32.0

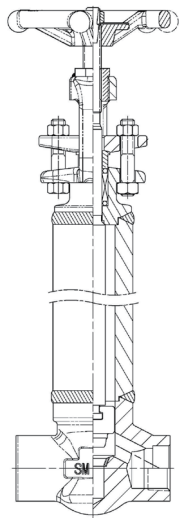

CG87

**CLASS 800 WELDED BONNET CRYOGENIC GLOBE VALVE  
THREADED or SOCKETWELD ENDS (IN.)**

VALVE SIZE NPS (DIN)	END TO END	CENTER TO TOP (OPEN)	HANDWHEEL DIAMETER	APPROX. WEIGHT LBS
1/2	3.25	18.38	4.00	10.9
3/4	3.50	18.56	4.00	12.6
1	4.50	18.81	4.00	16.4
1 1/2	6.25	20.06	5.50	24.2
2	7.25	22.12	6.63	38.3

**CG81  
CG83  
CG86**

## DIMENSIONAL DATA

Forged OS&Y - Conventional Port  
 Sizes: 1/2" - 2"  
 Pressure Class: 150/300/600  
 End Connections - Flanged

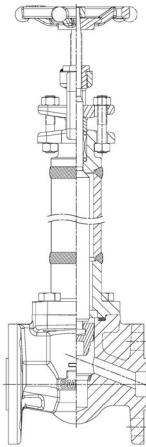

CG81

CLASS 150 BOLTED BONNET CRYOGENIC GLOBE VALVE FLANGED ENDS (IN.)				
VALVE SIZE NPS (DIN)	FACE TO FACE	CENTER TO TOP (OPEN)	HANDWHEEL DIAMETER	APPROX. WEIGHT LBS
1/2	4.25	18.88	4.00	10.8
3/4	4.63	19.06	4.00	13.3
1	5.00	20.25	4.00	15.2
1 1/2	6.50	21.12	5.50	25.0
2	7.00	23.00	6.63	42.2

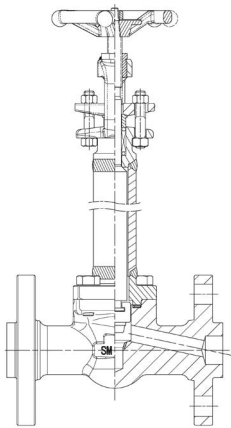

CG83

CLASS 300 BOLTED BONNET CRYOGENIC GLOBE VALVE FLANGED ENDS (IN.)				
VALVE SIZE NPS (DIN)	FACE TO FACE	CENTER TO TOP (OPEN)	HANDWHEEL DIAMETER	APPROX. WEIGHT LBS
1/2	5.50	18.19	4.00	11.3
3/4	6.00	18.38	4.00	14.5
1	6.50	19.81	4.00	18.2
1 1/2	7.50	21.13	5.50	31.3
2	8.50	23.00	6.63	44.2

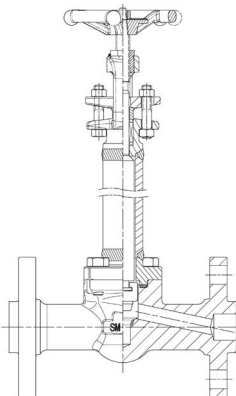

CG86

CLASS 600 BOLTED BONNET CRYOGENIC GLOBE VALVE FLANGED ENDS (IN.)				
VALVE SIZE NPS (DIN)	FACE TO FACE	CENTER TO TOP (OPEN)	HANDWHEEL DIAMETER	APPROX. WEIGHT LBS
1/2	6.50	18.19	4.00	11.8
3/4	7.50	18.38	4.00	16.0
1	8.50	19.81	4.00	20.5
1 1/2	9.50	21.12	5.50	37.2
2	11.50	23.00	6.63	53.9

# Y-PATTERN GLOBE VALVES

BOLTED OR WELDED BONNET



## DESIGN & CONSTRUCTION

- API 602 & ASME B16.34
- Bolted bonnet & welded bonnet designs
- Conventional and Full port
- Threaded, Socketweld & Buttweld ends class 800 & 1500
- Nameplate serialized for full traceability
- API 622 and API 624 qualified packing for low emissions
- Integral Stellite Seat
- Non-rising handwheel
- Stem with position indicator

- 01 INDICATOR NUT
- 02 HANDWHEEL
- 03 NAMEPLATE
- 04 YOKE NUT
- 05 GLAND NUT
- 06 GLAND
- 07 GLAND BOLT
- 08 BONNET BOLT
- 09 GASKET
- 10 STEM
- 11 LOCK PLATE
- 12 DISC WIRE
- 13 SEAT HARD FACE
- 14 BODY
- 15 LOCK WASHER
- 16 THRUST WASHER
- 17 GLAND FLANGE
- 18 PACKING SET
- 19 BONNET
- 20 DISC

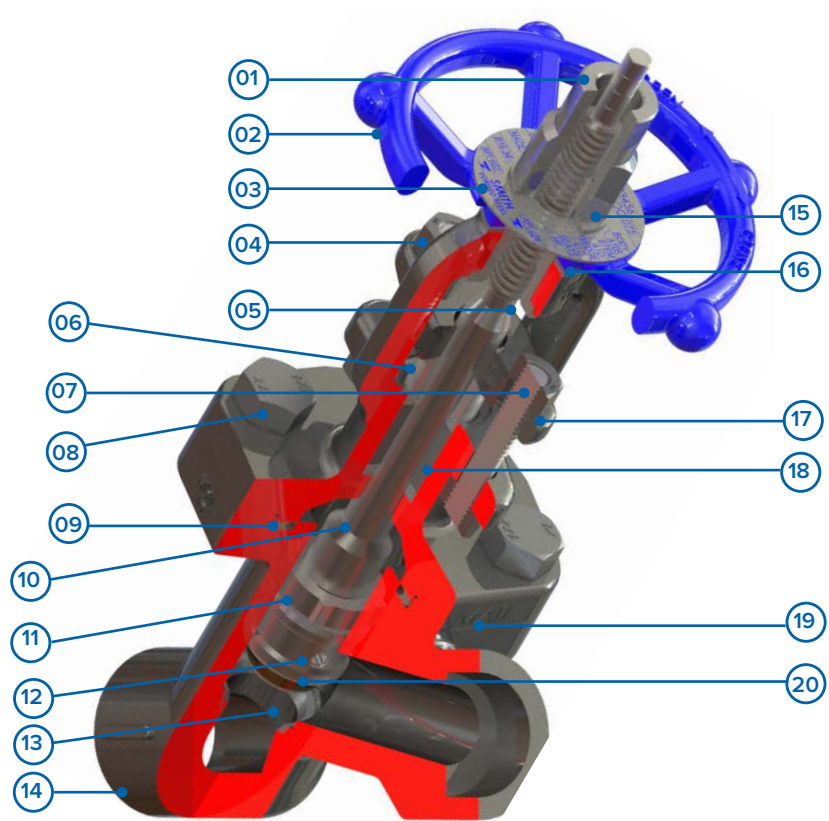

**YG80  
YG87**

## DIMENSIONAL DATA

Forged Globe OS&Y

Sizes: 1/2" - 2"

Pressure Class: 800

End Connections - Threaded or Socketweld

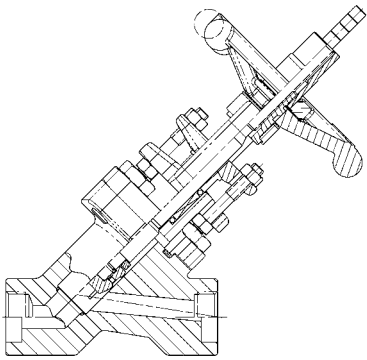

YG80

CLASS 800 BOLTED BONNET Y-PATTERN GLOBE VALVE - FULL PORT THREADED or SOCKETWELD ENDS (IN.)				
VALVE SIZE NPS (DN)	END TO END	CENTER TO TOP (OPEN)	HANDWHEEL DIAMETER	APPROX. WEIGHT LBS
1/2	4.72	6.23	4.0	5.8
3/4	4.72	6.23	4.0	5.7
1	5.12	7.52	5.5	9.0
1 1/2	7.17	10.12	6.6	20.4
2	7.68	10.75	6.6	26.0

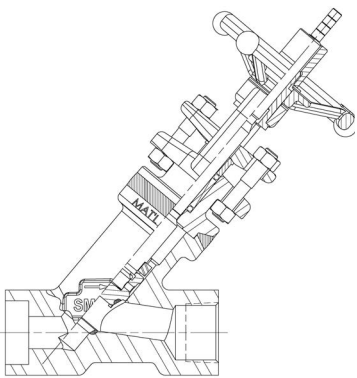

YG87

CLASS 800 WELDED BONNET Y-PATTERN GLOBE VALVE - CONVENTIONAL PORT THREADED or SOCKETWELD ENDS (IN.)				
VALVE SIZE NPS (DN)	END TO END	CENTER TO TOP (OPEN)	HANDWHEEL DIAMETER	APPROX. WEIGHT LBS
1/2	4.72	6.23	4.0	5.8
3/4	4.72	6.23	4.0	5.7
1	5.12	7.52	5.5	9.0
1 1/2	7.17	10.12	6.6	20.4
2	7.68	10.75	6.6	26.0

# YG15 YG17

## DIMENSIONAL DATA

Forged Globe OS&Y

Sizes: 1/2" - 2"

Pressure Class: 1500

End Connections - Threaded or Socketweld

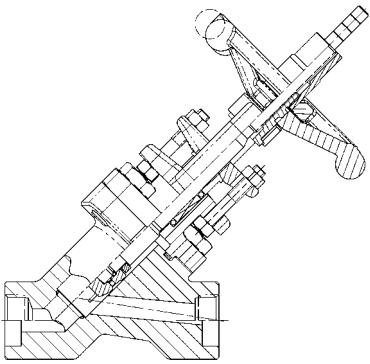

YG15

CLASS 1500 BOLTED BONNET Y-PATTERN GLOBE VALVE - FULL PORT  
THREADED or SOCKETWELD ENDS (IN.)

VALVE SIZE NPS (DN)	END TO END	CENTER TO TOP (OPEN)	HANDWHEEL DIAMETER	APPROX. WEIGHT LBS
1/2	4.72	6.23	4.0	5.8
3/4	4.72	6.23	4.0	5.7
1	5.12	7.52	5.5	9.0
1 1/2	7.17	10.12	6.6	20.4
2	7.68	10.75	6.6	26.0

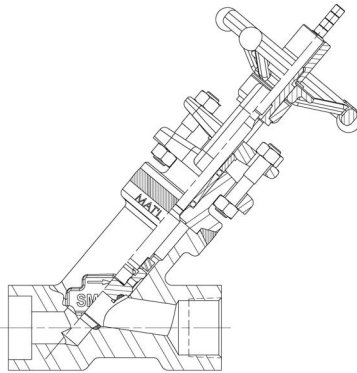

YG17

CLASS 1500 WELDED BONNET Y-PATTERN GLOBE VALVE - CONVENTIONAL PORT  
THREADED or SOCKETWELD ENDS (IN.)

VALVE SIZE NPS (DN)	END TO END	CENTER TO TOP (OPEN)	HANDWHEEL DIAMETER	APPROX. WEIGHT LBS
1/2	4.72	6.23	4.0	5.8
3/4	4.72	6.23	4.0	5.7
1	5.12	7.52	5.5	9.0
1 1/2	7.17	10.12	6.6	20.4
2	7.68	10.75	6.6	26.0

# Y-PATTERN GLOBE VALVES

## BONNETLESS DESIGN



### DESIGN & CONSTRUCTION

- API 598 & ASME B16.34
- Bonnetless design
- Full port
- Threaded, Socketweld, Buttweld, ends class 1690, 2690 & 4500
- Bonnet constructed of forged steel with integral backseat
- Nameplate serialized for full traceability
- Non-rising handwheel

- 01 HANDWHEEL
- 02 HANDWHEEL NUT
- 03 STEM
- 04 PACKING
- 05 PACKING RING
- 06 BACK SEAT BUSHING
- 07 BACK SEAT RING
- 08 DISC WIRE
- 09 DISC
- 10 GLAND STUD NUT
- 11 GLAND FLANGE
- 12 GLAND BUSHING
- 13 THRUST BEARING
- 14 YOKE NUT
- 15 YOKE NUT RETAINER
- 16 YOKE
- 17 BODY
- 18 SEAT HARD FACE
- 19 NAMEPLATE
- 20 GREASE FITTING

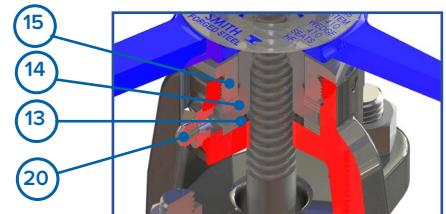
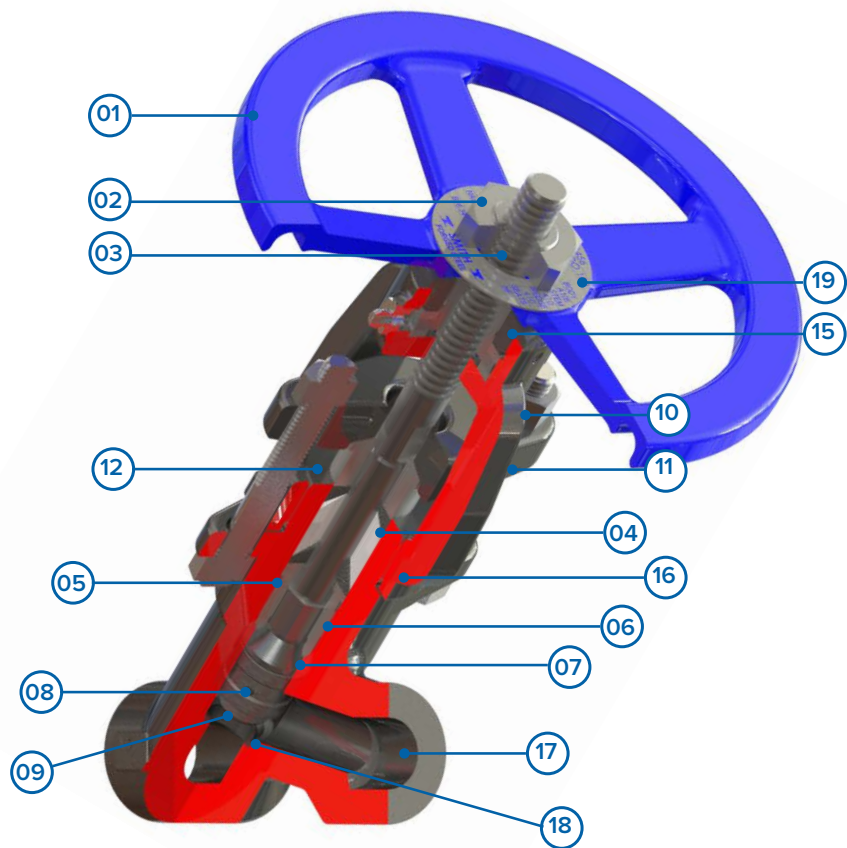



**Y162  
Y262  
Y452**

## DIMENSIONAL DATA

Forged Y-Globe OS&Y - Full Port  
 Sizes: 1/2" - 2"

Pressure Class: 1690/2690/4500

End Connections - Threaded, Socketweld, or Buttweld

Needle Globe Option

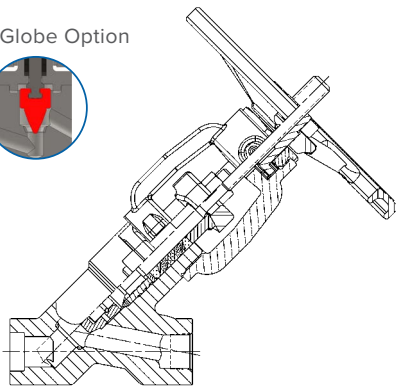
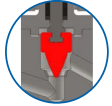

Y162

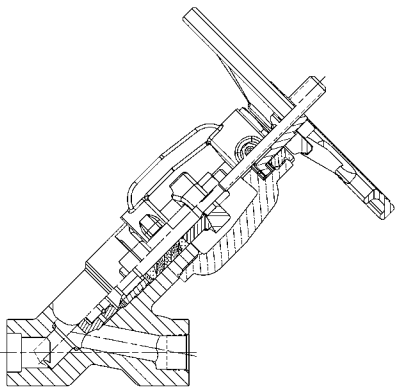

Y262

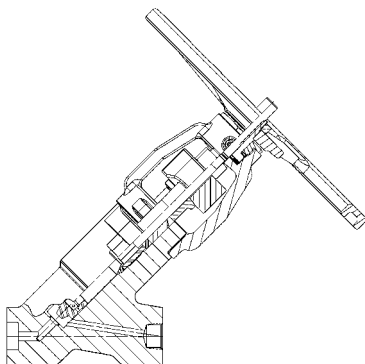

Y452

### CLASS 1690 BONNETLESS Y-PATTERN GLOBE VALVE THREADED, SOCKETWELD or BUTTWELD ENDS (IN.)

VALVE SIZE NPS (DN)	END TO END	CENTER TO TOP (OPEN)	HANDWHEEL DIAMETER	APPROX. WEIGHT LBS
1/2	5.51	11.3	9.8	22
3/4	5.51	11.3	9.8	22
1	6.30	11.9	9.8	27
1 1/4	8.27	17.6	15.7	85
1 1/2	8.27	17.6	15.7	85
2	10.24	21.3	19.7	138

### CLASS 2690 BONNETLESS Y-PATTERN GLOBE VALVE THREADED, SOCKETWELD or BUTTWELD ENDS (IN.)

VALVE SIZE NPS (DN)	END TO END	CENTER TO TOP (OPEN)	HANDWHEEL DIAMETER	APPROX. WEIGHT LBS
1/2	5.51	11.3	9.8	22
3/4	5.51	11.3	9.8	22
1	6.30	11.9	9.8	27
1 1/4	8.27	17.6	15.7	85
1 1/2	8.27	17.6	15.7	85
2	10.24	21.3	19.7	138

### CLASS 4500 BONNETLESS Y-PATTERN GLOBE VALVE SOCKETWELD or BUTTWELD ENDS (IN.)

VALVE SIZE NPS (DN)	END TO END	CENTER TO TOP (OPEN)	HANDWHEEL DIAMETER	APPROX. WEIGHT LBS
1/2	8.27	17.6	15.7	89
3/4	8.27	17.6	15.7	89
1	10.24	21.3	19.7	145

# PISTON CHECK VALVES

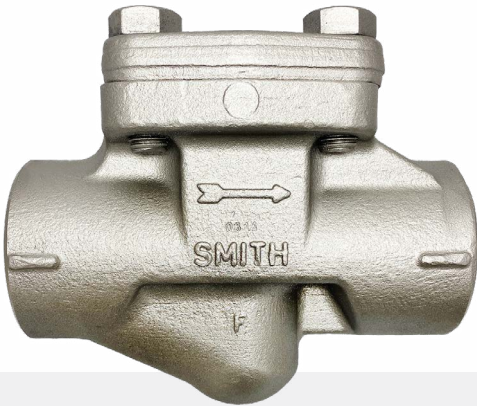

## DESIGN & CONSTRUCTION

Smith Piston Check Valves are available in non-spring loaded or spring loaded design in class 150-1500 and feature conventional ports. Available in bolted or welded caps with either threaded, socketweld or RF ends. All are manufactured in accordance with API 602 and ASME B16.34 standards.

- 01 BONNET BOLT
- 02 CAP
- 03 BODY
- 04 SPRING
- 05 NAMEPLATE
- 06 GASKET
- 07 PISTON
- 08 SEAT

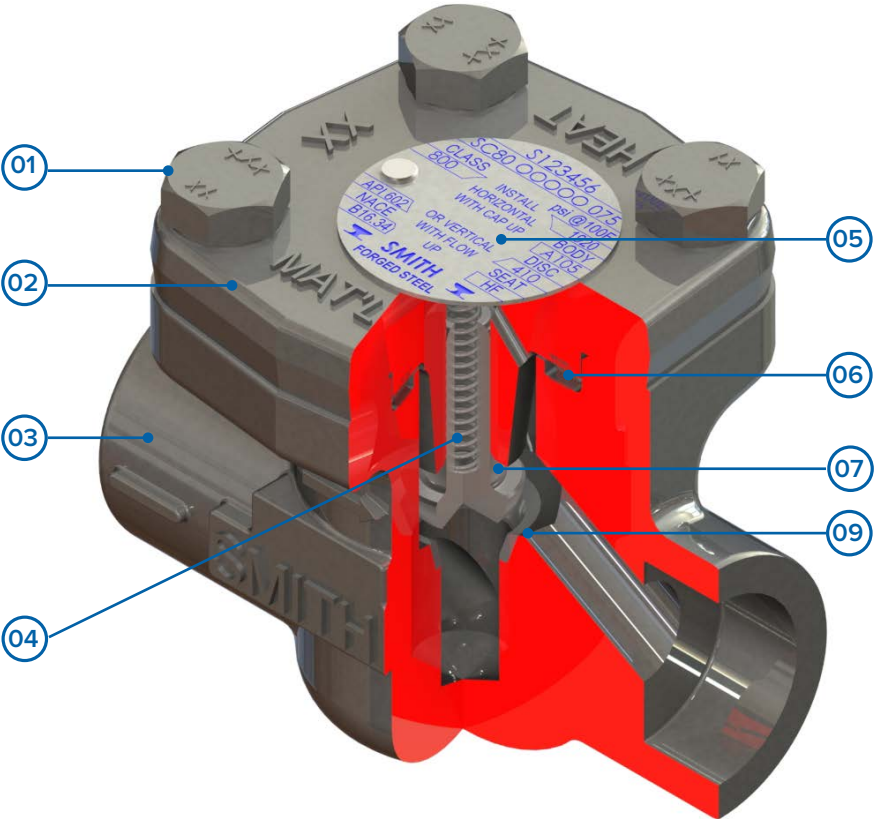

OC80  
SC80  
OC87  
SC87

## DIMENSIONAL DATA

Forged OS&Y - Conventional Port

Sizes: 1/4" - 2"

Pressure Class: 800

End Connections - Threaded or Socketweld

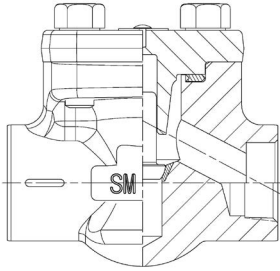

OC80

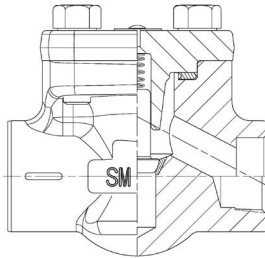

SC80

OC80/SC80 - CL800 BOLTED CAP PISTON CHECK THREADED or SOCKETWELD ENDS (IN.)			
VALVE SIZE NPS	END TO END	CENTER TO TOP	APPROX. WEIGHT LBS
1/4	3.25	2.00	2.50
3/8	3.25	2.00	2.50
1/2	3.25	2.00	2.30
3/4	3.50	2.25	3.30
1	4.50	2.25	5.00
1 1/4	6.25	2.88	10.50
1 1/2	6.25	2.88	10.00
2	7.25	3.56	18.30

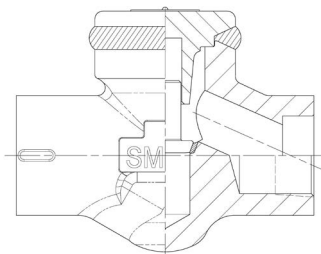

OC87

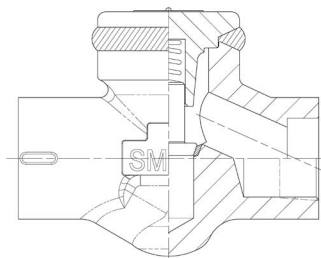

SC87

OC87/SC87 - CL800 WELDED CAP PISTON CHECK THREADED or SOCKETWELD ENDS (IN.)			
VALVE SIZE NPS	END TO END	CENTER TO TOP	APPROX. WEIGHT LBS
1/2	3.25	1.88	2.00
3/4	3.50	2.13	2.90
1	4.50	2.19	4.50
1 1/2	6.25	2.76	9.00
2	7.25	3.56	16.40

**C150  
SC15  
C157  
SC17**

## DIMENSIONAL DATA

Forged OS&Y - Conventional Port

Sizes: 1/4" - 2"

Pressure Class: 1500

End Connections - Threaded or Socketweld

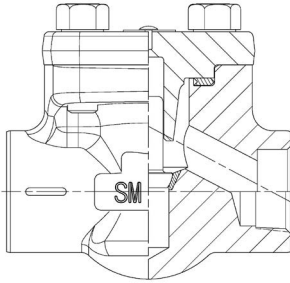

C150

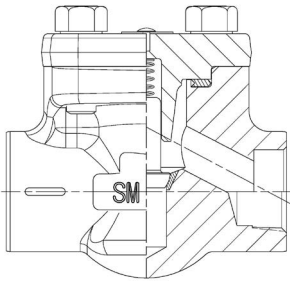

SC15

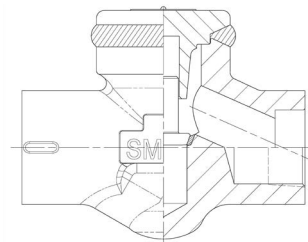

C157

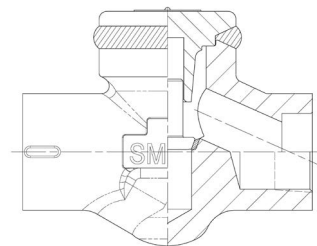

SC17

**C150/SC15 - CL1500 BOLTED CAP PISTON CHECK  
THREADED or SOCKETWELD ENDS (IN.)**

VALVE SIZE NPS	END TO END	CENTER TO TOP	APPROX. WEIGHT LBS
1/4	3.50	2.38	4.80
3/8	3.50	2.38	4.80
1/2	3.50	2.38	4.50
3/4	4.50	2.44	7.00
1	6.25	3.13	12.80
1 1/4	7.25	3.94	22.50
1 1/2	7.25	3.91	22.20
2	7.25	4.50	26.50

**C157/SC57 - CL1500 WELDED CAP SPRING PISTON CHECK  
THREADED or SOCKETWELD ENDS (IN.)**

VALVE SIZE NPS	END TO END	CENTER TO TOP	APPROX. WEIGHT LBS
1/2	3.50	2.26	4.50
3/4	4.50	2.44	6.30
1	6.25	3.07	11.50
1 1/2	7.25	3.93	20.70
2	7.25	4.03	23.90

**OC81  
SC81  
OC83  
SC83**

## DIMENSIONAL DATA

Forged OS&Y - Conventional Port  
 Sizes: 1/2" - 2"  
 Pressure Class: 150 and 300  
 End Connections - Flanged

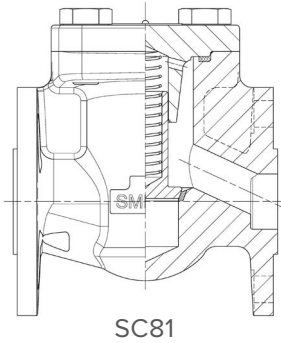
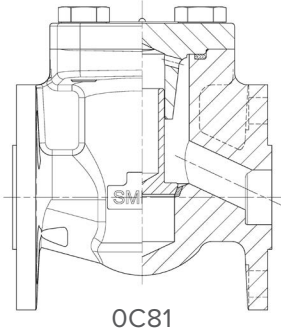

OC81/SC81 - CL150 BOLTED CAP PISTON CHECK FLANGED ENDS (IN.)			
VALVE SIZE NPS	END TO END	CENTER TO TOP	APPROX. WEIGHT LBS
1/2	4.25	2.83	4.40
3/4	4.61	3.00	5.50
1	5.00	3.66	8.80
1 1/2	6.50	4.37	17.60
2	8.00	3.58	24.10

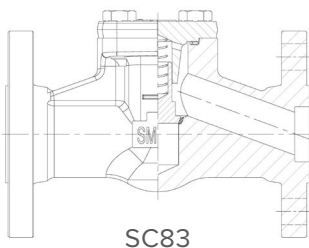
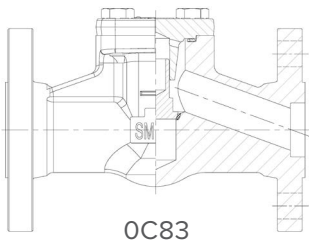

OC83/SC83 - CL300 BOLTED CAP SPRING PISTON CHECK FLANGED ENDS (IN.)			
VALVE SIZE NPS	END TO END	CENTER TO TOP	APPROX. WEIGHT LBS
1/2	6.00	2.00	5.80
3/4	7.00	2.25	9.50
1	8.00	2.63	13.30
1 1/2	9.00	3.69	28.80
2	10.50	4.25	37.00

OC86  
SC86  
OC89  
SC89

## DIMENSIONAL DATA

Forged OS&Y - Conventional Port  
 Sizes: 1/2" - 2"  
 Pressure Class: 600 and 1500  
 End Connections - Flanged

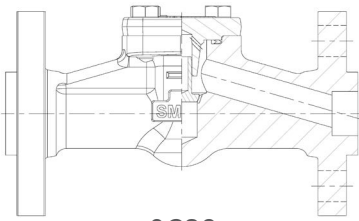

OC86

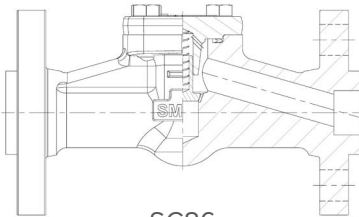

SC86

OC86/SC86 - CL600 BOLTED CAP PISTON CHECK FLANGED ENDS (IN.)			
VALVE SIZE NPS	END TO END	CENTER TO TOP	APPROX. WEIGHT LBS
1/2	6.50	2.00	6.30
3/4	7.50	2.25	10.50
1	8.50	2.63	13.50
1 1/2	9.50	3.69	29.50
2	11.50	4.25	43.50

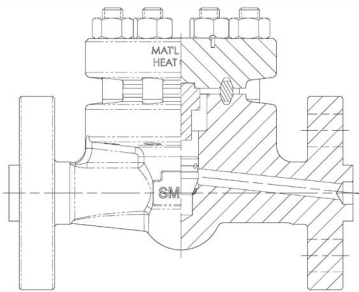

OC89

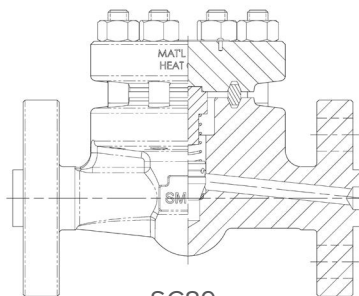

SC89

OC89/SC89 - CL1500 BOLTED CAP PISTON CHECK FLANGED ENDS (IN.)			
VALVE SIZE NPS	END TO END	CENTER TO TOP	APPROX. WEIGHT LBS
1/2	8.50	4.56	23.00
3/4	9.00	4.56	25.90
1	10.00	4.93	37.80
1 1/2	12.01	6.52	71.10
2	14.49 (RF) 14.61 (RTJ)	7.77	131.90

# SC29

## DIMENSIONAL DATA

Forged OS&Y - Conventional Port  
 Sizes: 1/2" - 1"  
 Pressure Class: 2500  
 End Connections - Flanged

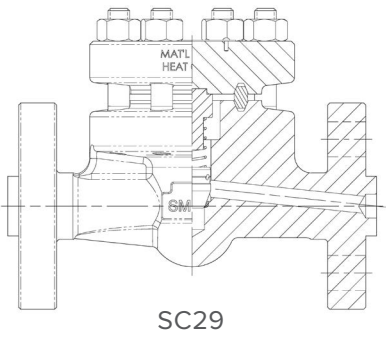

SC29 - CL2500 BOLTED CAP SPRING PISTON CHECK FLANGED ENDS (IN.)			
VALVE SIZE NPS	END TO END	CENTER TO TOP	APPROX. WEIGHT LBS
1/2	8.50	4.56	23.00
3/4	9.00	4.56	25.90
1	10.00	4.93	37.80
1 1/2	12.01	6.52	71.10
2	14.49 (RF) 14.61 (RTJ)	7.77	131.90

# BALL CHECK VALVES



## DESIGN & CONSTRUCTION

Smith Ball Check Valves are available in non-spring loaded or spring loaded design in Class 150-1500 and feature conventional ports. Available in bolted or welded caps with either threaded, socketweld or RF ends. All are manufactured in accordance with API 602 and ASME B16.34 standards.

- 01 BONNET BOLT
- 02 CAP
- 03 BODY
- 04 SPRING
- 05 CAGE
- 06 NAMEPLATE
- 07 GASKET
- 08 BALL
- 09 SEAT

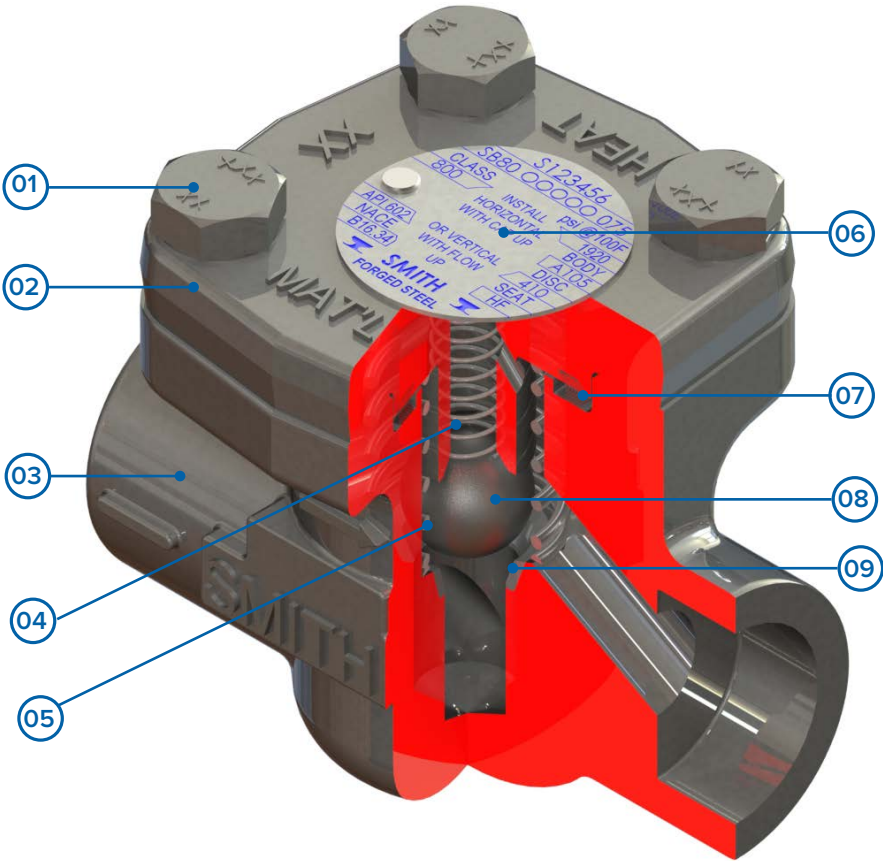



**OB80  
SB80  
OB87  
SB87**

## DIMENSIONAL DATA

Forged OS&Y - Conventional Port  
Sizes: 1/4" - 2"

Pressure Class: 800

End Connections - Threaded or Socketweld

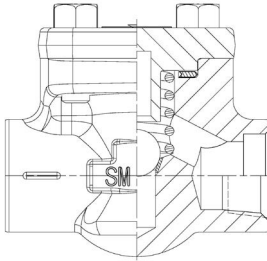

OB80

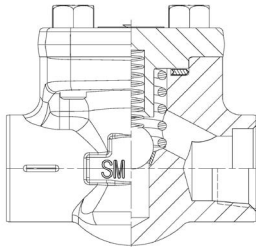

SB80

OB80/SB80 CL800 BOLTED CAP BALL CHECK THREADED or SOCKETWELD ENDS (IN.)			
VALVE SIZE NPS	END TO END	CENTER TO TOP	APPROX. WEIGHT LBS
1/4	3.25	2.00	2.50
3/8	3.25	2.00	2.50
1/2	3.25	2.00	2.30
3/4	3.50	2.25	3.30
1	4.50	2.25	5.00
1 1/4	6.25	2.88	10.50
1 1/2	6.25	2.88	10.00
2	7.25	3.56	18.30

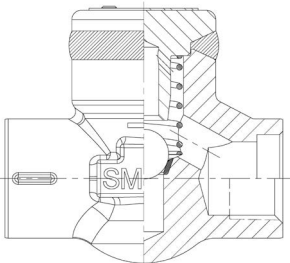

OB87

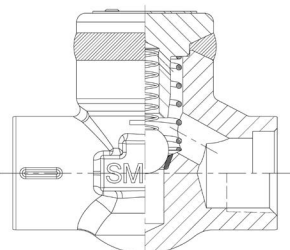

SB87

OB87/SB87 CL800 WELDED CAP BALL CHECK THREADED or SOCKETWELD ENDS (IN.)			
VALVE SIZE NPS	END TO END	CENTER TO TOP	APPROX. WEIGHT LBS
1/2	3.25	1.88	2.00
3/4	3.50	2.13	2.90
1	4.50	2.19	4.50
1 1/2	6.25	2.76	9.00
2	7.25	3.56	16.40

**B150  
SB15  
OB17  
SB17**

## DIMENSIONAL DATA

Forged OS&Y - Conventional Port  
Sizes: 1/4" - 2"

Pressure Class: 1500

End Connections - Threaded or Socketweld

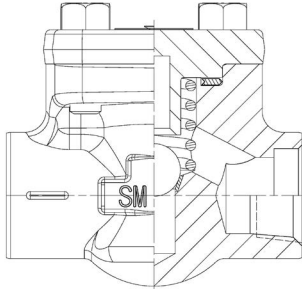

B150

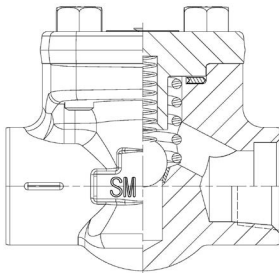

SB15

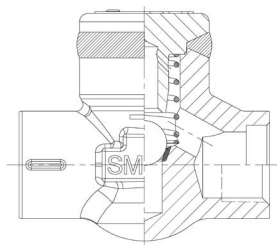

OB17

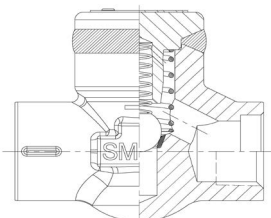

SB17

**B150/SB15 - CL1500 BOLTED CAP BALL CHECK  
THREADED or SOCKETWELD ENDS (IN.)**

VALVE SIZE NPS	END TO END	CENTER TO TOP	APPROX. WEIGHT LBS
1/4	3.50	2.38	4.80
3/8	3.50	2.38	4.80
1/2	3.50	2.38	4.50
3/4	4.50	2.44	7.00
1	6.25	3.13	12.80
1 1/4	7.25	3.94	22.50
1 1/2	7.25	3.94	22.30
2	7.25	4.50	26.50

**OB17/SB17 - CL1500 WELDED CAP BALL CHECK  
THREADED or SOCKETWELD ENDS (IN.)**

VALVE SIZE NPS	END TO END	CENTER TO TOP	APPROX. WEIGHT LBS
1/2	3.50	2.26	4.10
3/4	4.50	2.44	6.30
1	6.25	3.07	11.50
1 1/2	7.25	3.93	20.70
2	7.25	4.03	23.90

**OB81  
SB81  
OB83  
SB83**

## DIMENSIONAL DATA

Forged OS&Y - Conventional Port  
 Sizes: 1/2" - 2"  
 Pressure Class: 150 and 300  
 End Connections - Flanged

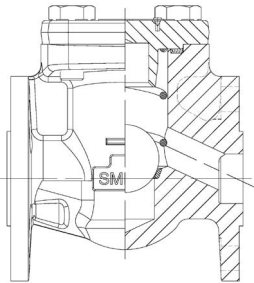

OB81

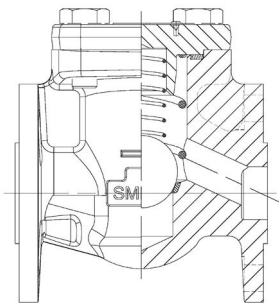

SB81

OB81/SB81 - CL150 BOLTED CAP BALL CHECK FLANGED ENDS (IN.)			
VALVE SIZE NPS	END TO END	CENTER TO TOP	APPROX. WEIGHT LBS
1/2	4.25	2.83	4.40
3/4	4.61	3.00	5.50
1	5.00	3.66	8.80
1 1/2	6.50	4.37	17.60

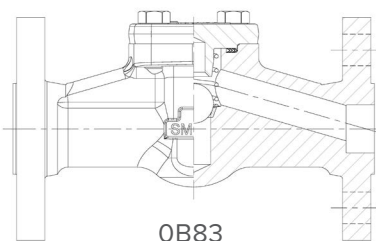

OB83

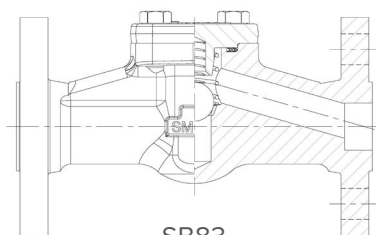

SB83

OB83/SB83 - CL300 BOLTED CAP BALL CHECK FLANGED ENDS (IN.)			
VALVE SIZE NPS	END TO END	CENTER TO TOP	APPROX. WEIGHT LBS
1/2	6.00	2.00	5.80
3/4	7.00	2.50	9.50
1	8.00	2.63	13.30
1 1/2	9.00	3.69	28.80
2	10.50	4.25	37.00

**OB86  
SB86  
OB89  
SB89**

## DIMENSIONAL DATA

Forged OS&Y - Conventional Port  
 Sizes: 1/2" - 2"  
 Pressure Class: 600 and 1500  
 End Connections - Flanged

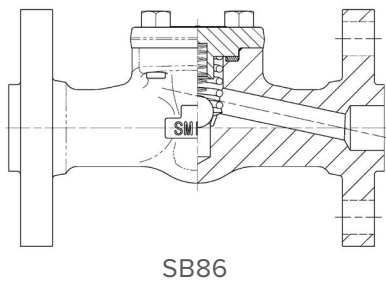
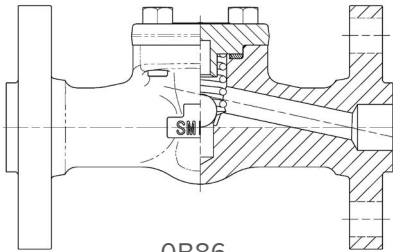

OB86/SB86 - CL600 BOLTED CAP BALL CHECK FLANGED ENDS (IN.)			
VALVE SIZE NPS	END TO END	CENTER TO TOP	APPROX. WEIGHT LBS
1/2	6.50	2.00	6.30
3/4	7.50	2.25	10.50
1	8.50	2.63	13.50
1 1/2	9.50	3.69	29.50
2	11.50	4.25	43.50

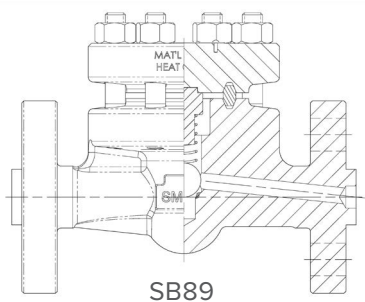
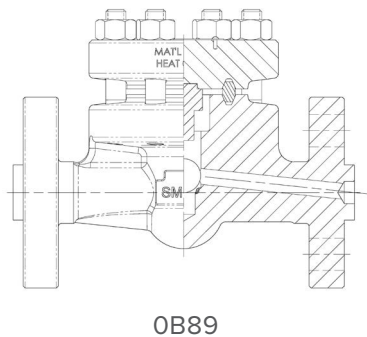

OB89/SB89 - CL1500 BOLTED CAP BALL CHECK FLANGED ENDS (IN.)			
VALVE SIZE NPS	END TO END	CENTER TO TOP	APPROX. WEIGHT LBS
1/2	8.50	4.56	23.0
3/4	9.00	4.56	25.9
1	10.00	4.93	37.8
1 1/2	12.01	6.52	71.1
2	14.49 (RF) 14.61 (RTJ)	7.77	131.9

# SB29

## DIMENSIONAL DATA

Forged OS&Y - Conventional Port  
 Sizes: 1/2" - 2"  
 Pressure Class: 2500  
 End Connections - Flanged

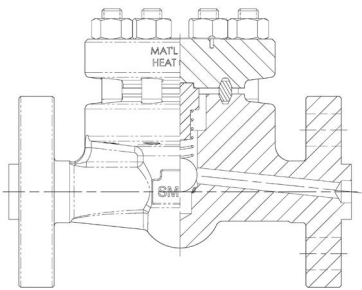

SB29

SB29 - CL2500 BOLTED CAP SPRING BALL CHECK FLANGED ENDS (IN.)			
VALVE SIZE NPS	END TO END	CENTER TO TOP	APPROX. WEIGHT LBS
1/2	8.50	4.56	23.0
3/4	9.00	4.56	25.9
1	10.00	4.93	37.8
1 1/2	12.01	6.52	71.1
2	14.49 (RF) 14.61 (RTJ)	7.77	131.9

# SWING CHECK VALVES



## DESIGN & CONSTRUCTION

Smith Swing Check Valves are available in Class 150-600 & 800 and feature conventional ports with bolted caps. Available in either threaded, socketweld or RF ends. All are manufactured in accordance with API 602 and ASME B16.34 standards.

- 01 BONNET BOLT
- 02 CAP
- 03 BODY
- 04 RETAINING PIN
- 05 NAMEPLATE
- 06 SPRING PIN
- 07 GASKET
- 08 SEAT RING & DISC
- 09 HANGER
- 10 PIN

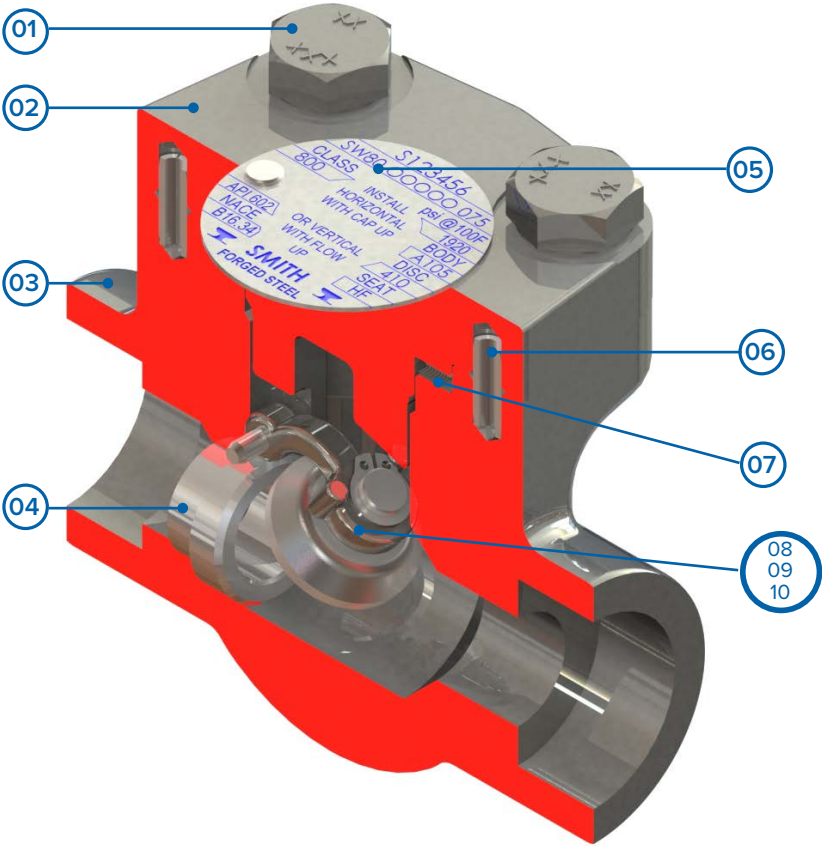

# SW80 SW81

## DIMENSIONAL DATA

Forged OS&Y - Conventional Port

Sizes: 1/2" - 2

Pressure Class: 150, 800

End Connections - Threaded, Socketweld, Flanged

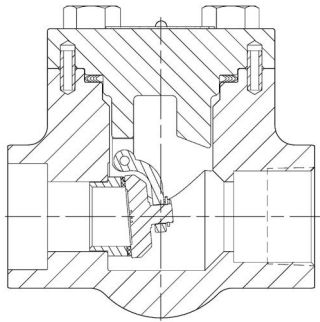

SW80

SW80 - CL800 BOLTED CAP SWING CHECK THREADED or SOCKETWELD ENDS (IN.)			
VALVE SIZE NPS	END TO END	CENTER TO TOP	APPROX. WEIGHT LBS
1/2	3.25	1.96	2.20
3/4	3.50	2.23	3.20
1	3.88	2.66	4.40
1 1/2	4.75	3.72	8.30
2	5.50	4.39	16.10

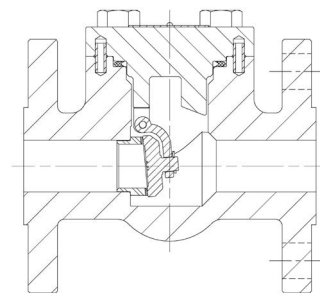

SW81

SW81 - CL150 BOLTED CAP SWING CHECK FLANGED ENDS (IN.)			
VALVE SIZE NPS	END TO END	CENTER TO TOP	APPROX. WEIGHT LBS
1/2	4.25	2.62	4.60
3/4	4.61	2.82	6.60
1	5.00	3.03	8.50
1 1/2	5.50	3.67	14.10
2	7.99	4.31	25.60

# SW83 SW86

## DIMENSIONAL DATA

Forged OS&Y - Conventional Port  
 Sizes: 1/2" - 2"  
 Pressure Class: 300 and 600  
 End Connections - Flanged

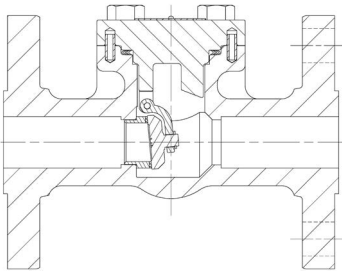

SW83

SW83 - CL300 BOLTED CAP SWING CHECK FLANGED ENDS (IN.)			
VALVE SIZE NPS	END TO END	CENTER TO TOP	APPROX. WEIGHT LBS
1/2	5.98	1.93	5.40
3/4	7.01	2.20	8.70
1	7.99	2.63	11.90
1 1/2	9.02	3.67	23.50
2	10.51	4.31	33.40

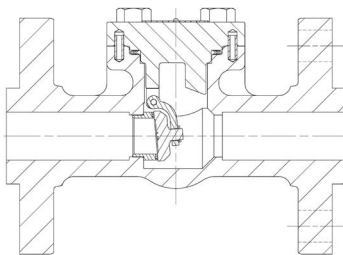

SW86

SW86 - CL600 BOLTED CAP SWING CHECK FLANGED ENDS (IN.)			
VALVE SIZE NPS	END TO END	CENTER TO TOP	APPROX. WEIGHT LBS
1/2	6.50	1.93	5.90
3/4	7.48	2.20	9.30
1	8.50	2.63	12.70
1 1/2	9.49	3.67	26.20
2	11.50	4.31	37.50



# UNION BALL CHECK VALVE

UB80



## DESIGN & CONSTRUCTION

Smith vertical union cap check valves are available in Class 800 and feature conventional port with threaded caps. Available in either threaded or socketweld ends. All are manufactured in accordance with API 602 and ASME B16.34 standards. Tested to API 598

- 01 CAP
- 02 NAMEPLATE
- 03 GASKET
- 04 BALL
- 05 SEAT
- 06 BODY
- 07 THREADED LOCK NUT

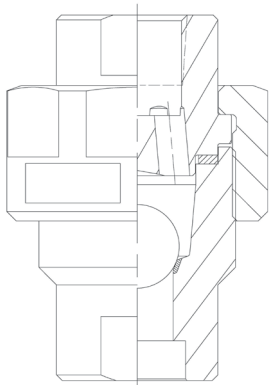
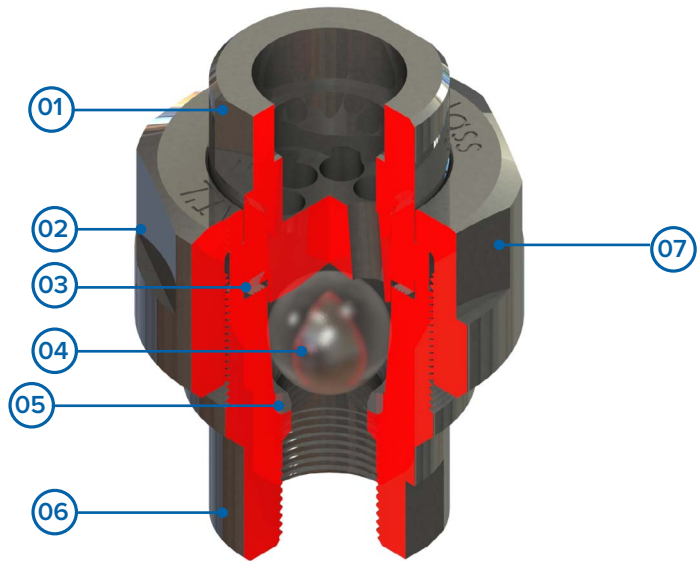

UB80

CLASS 800 VERTICAL UNION BALL TYPE CHECK VALVE THREADED or SOCKETWELD ENDS (IN.)			
VALVE SIZE NPS	END TO END	CENTER TO TOP	APPROX. WEIGHT LBS
1/2	3.38	2.33	2.10
3/4	3.82	2.72	3.10

# Y-PATTERN CHECK VALVES

BOLTED / WELDED CAP



## DESIGN & CONSTRUCTION

Smith Y-Pattern Piston & Ball Check Valves are available in Class 800, 1500. Available in bolted design in conventional port with either threaded or socketweld ends. All are manufactured in accordance with API 602 and ASME B16.34 standards.

- 01 BONNET BOLT
- 02 GASKET
- 03 SPRING
- 04 DISC
- 05 BODY
- 06 NAMEPLATE
- 07 CAP
- 08 SEAT

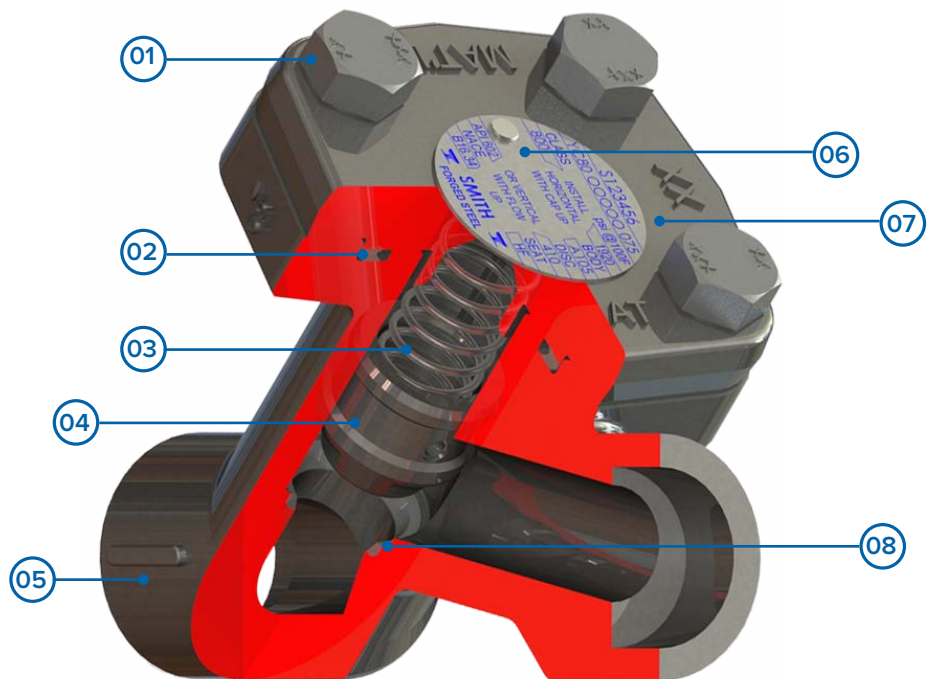

**YC80  
YC87  
YC15**

## DIMENSIONAL DATA

Forged OS&Y - Conventional Port

Sizes: 1/2" - 2"

Pressure Class: 800 and 1500

End Connections - Threaded or Socketweld

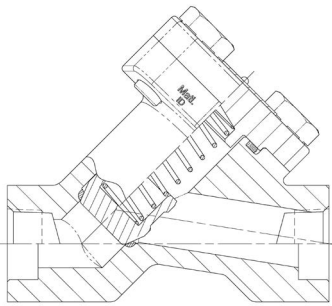

YC80

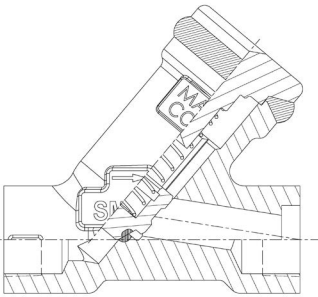

YC87

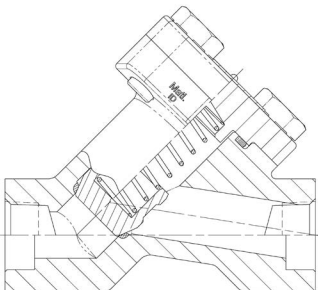

YC15

### YC80/YC87 - CL800 BOLTED / WELDED CAP Y-PATTERN PISTON CHECK THREADED or SOCKETWELD ENDS (IN.)

VALVE SIZE NPS	END TO END	CENTER TO TOP	APPROX. WEIGHT LBS
1/2	4.72	3.25	4.10
3/4	4.72	3.24	3.80
1	5.12	3.78	5.60
1 1/2	7.17	5.14	14.50
2	7.68	5.62	19.40

### YC15 - CL1500 BOLTED CAP Y-PATTERN PISTON CHECK THREADED or SOCKETWELD ENDS

VALVE SIZE NPS	END TO END	CENTER TO TOP	APPROX. WEIGHT LBS
1/2	4.72	3.38	4.50
3/4	5.12	3.89	6.40
1	7.17	5.27	17.70
1 1/2	7.68	6.00	24.80
2	7.68	6.02	24.00

**YB80  
YB87  
YB15**

**DIMENSIONAL DATA**

Forged OS&Y - Conventional Port

Sizes: 1/2" - 2"

Pressure Class: 800 and 1500

End Connections - Threaded or Socketweld

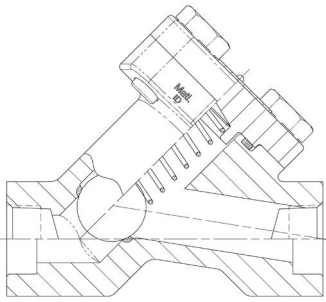

YB80

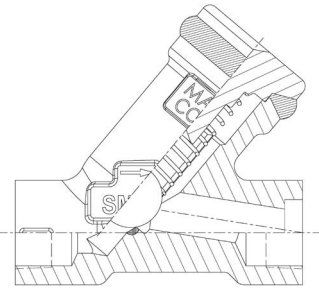

YB87

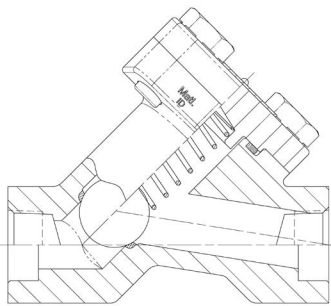

YB15

**YB80/YB87 - CL800 BOLTED / WELDED CAP Y-PATTERN PISTON CHECK  
THREADED or SOCKETWELD ENDS (IN.)**

VALVE SIZE NPS	END TO END	CENTER TO TOP	APPROX. WEIGHT LBS
1/2	4.72	3.25	4.10
3/4	4.72	3.24	3.80
1	5.12	3.78	5.60
1 1/2	7.17	5.14	14.80
2	7.68	5.62	19.90

**YB15 - CL1500 BOLTED CAP Y-PATTERN BALL CHECK  
THREADED or SOCKETWELD ENDS**

VALVE SIZE NPS	END TO END	CENTER TO TOP	APPROX. WEIGHT
1/2	4.72	3.25	4.10
3/4	5.12	3.24	3.80
1	7.17	3.78	5.60
1 1/2	7.68	5.14	14.80

# Y-PATTERN CHECK VALVES

## THREADED CAP



### DESIGN & CONSTRUCTION

Smith Y-Pattern Piston Check Valves are available in Class 1690 & 2690. Available in conventional port with either threaded or socketweld ends. All are manufactured in accordance with API 602 and ASME B16.34 standards.

- 01 CAP
- 02 GASKET
- 03 SPRING
- 04 BODY
- 05 PISTON
- 06 SEAT

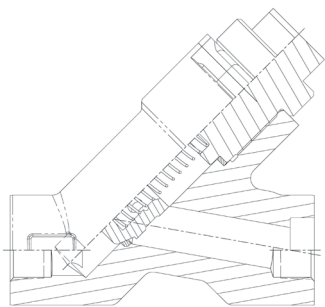
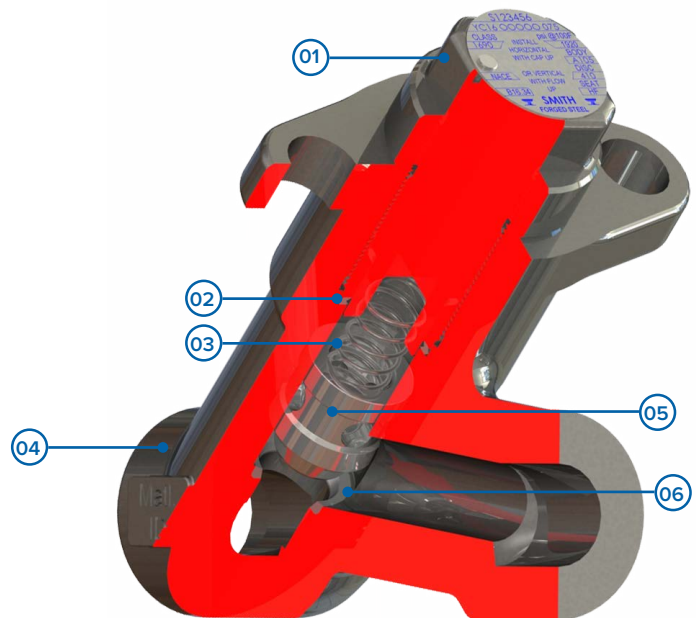

YC16/YC26 - CL1690/2690 THREADED CAP Y-PATTERN SPRING PISTON CHECK SOCKETWELD ENDS (IN.)			
VALVE SIZE NPS	END TO END	CENTER TO TOP	APPROX. WEIGHT LBS
1/2	5.51	4.53	8.00
3/4	5.51	4.53	20.00
1	6.30	5.01	19.40
1 1/2	8.27	7.12	28.00
2	10.24	9.52	51.00

# Part Numbering System

## Valve Material Option Codes

(PREFIX) + STYLE CODE (Reference pages 72-73) + MATERIAL SELECTION PER TABLE BELOW

**C E B 8 0 0 O S O**

	BODY/BONNET COVER	API TRIM #	TRIM MATERIAL			PACKING	SPRING <sup>6</sup>	
			STEM	WEDGE/DISC <sup>7</sup>	SEAT <sup>7</sup>			
A	A182-F51	A	10	316	316	316	A	GRAPHITE V-RINGS
B	A182-F347	B	11	MONEL	MONEL	HF	B	
C	A182-F5	C		MONEL K500	MONEL	MONEL	C	CHESTERTON 1600
D	A182-F316H	D	9	MONEL NACE	MONEL NACE	MONEL NACE	D	
E	B564-N10276	E		INCONEL 625	HF	HF	E	GARLOCK EVSP 9000
F	B462-N08020	F	13	ALLOY 20	ALLOY 20	ALLOY 20	F	
G	A182-F9	G		317L	317L	HF	G	
H	A182-F321	H		347H	HF	HF	H	
I	A182-F347H	I		347H	347H	HF	I	INCONEL X-750 <sup>6</sup>
J	A182-F316DC	J		316H	316H	HF	J	
K	A182-F11, CL.2	K		410 NACE	420 NACE	HF	K	
L	A182-F317DC	L		321	HF	HF	L	
M	B564-N06625	M		316H	HF	HF	M	BRAIDED TFE
N	A182-F22, CL.3	N		304L	304L	HF	N	
O	A105 <sup>2</sup>	O	8	410	420	HF	O	GRAPHITE W/BRAIDED ENDS <sup>6</sup>   302/316L <sup>6</sup>
P	A182-F91	P		INCOLOY 825	HF	HF	P	
Q	B564-N04400	Q	18	ALLOY 20	HF	HF	Q	
R	A182-F304DC	R		F51	F51	HF	R	
S	A105 <sup>2</sup>	S	12	316	316	HF	S	SLADE 3300G
T	A350-LF2, CL.1 <sup>3</sup>	T	5	410	HF	HF	T	
U	A350-LF2, CL.1 <sup>3</sup>	U		F53	HF	HF	U	
V	A182-F304H	V		304H	304H	HF	V	TFE V-RINGS VACUUM
W	B564-N08825	W	16	316	HF	HF	W	GARLOCK - GRAPHITE W/ CERAMIC RING
X	A182-F53	X		HAST - C276	HAST - C276	HAST - C276	X	TFE V-RINGS
Y	A105 <sup>2</sup>	Y		304H	HF	HF	Y	
Z	***	Z	***	***	***	***	Z	***

1. For ASTM material specification, refer to EDC 001 for body/bonnet, EDC 006 for stem, EDC 005 for wedge/disc, EDC 004 for seat, EDC 019 for packing, EDC 011 for spring

2. For A105 Body/Bonnet/Cover use O for Standard service, S for HF acid service, and Y for NACE service.

3. For A350-LF2, Cl. 1 Body/Bonnet/Cover use T for Standard service, and U for NACE service.

4. For all welded valves, use "O" for the gasket code.

5. Wedges/discs base material shall be compatible with the pressure/temperature rating and at least equal in corrosion resistance as the body material.

+ VALVE SIZE - MANUFACTURING CODE (SUFFIX)

**G W 1 0 0 - # # # #**

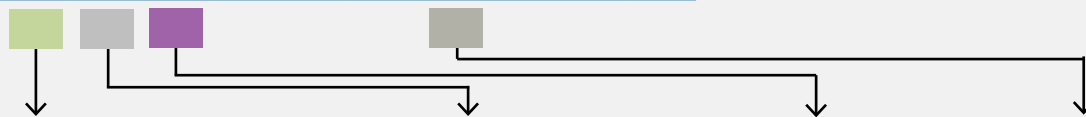

GASKET		END CONNECTIONS		SIZE		MODIFICATION CODE <sup>10</sup>	
A	INCOLOY 825 + GRAPHITE	A	BWE SCH. 10	025	1/4 NPS / 8 DN	0A00	Bellows: 304
B	INCONEL 600/X750 + GRAPHITE	B	BWE SCH.20	037	3/8 NPS / 10 DN	0B00	Bellows: 304L
C		C	BWE SCH. 40	050	1/2 NPS / 15 DN	0C00	Bellows: 316
D	INCONEL 600/X750 + TFE	D	BWE SCH. 80	075	3/4 NPS / 20 DN	0D00	Bellows: 316L
E		E	BWE SCH.100	100	(1 NPS / 25 DN	0E00	Bellows: 321
F	ALLOY 20 + GRAPHITE	F	BWE SCH.160	125	1 1/4 NPS 40 DN	0F00	Bellows: 347
G	316 + GRAPHITE	G	BWE SCH. 180	150	1 1/2 / 40 DN	0G00	Bellows: Inconel 625
H	HAST - C276 + GRAPHITE	H	BWE SCH. XXS	200	2 NPS / 50 DN	0H00	Bellows: Monel 400
I	347H + GRAPHITE	I		300	3 NPS / 80 DN)	000B	Special Clean (oxygen cleaned)
J		J	RING TYPE JOINT (RTJ)			000G	Gear operated
K		K				000H	RF to FF conversion
L	317L + GRAPHITE	L				000K	Actuator Operated
M	MONEL + GRAPHITE	M				000L	Live Loaded Packing
N		N				000M	Acid Shield
O	316/316L + GRAPHITE OR NO GASKET <sup>4</sup>	O	F- NPT THD RAISED FACE MALE EXTENSIONS			000R	RT 100% Critical Area
P	X750 + THERMICULITE 835	P	PLAIN END FLANGE			000T	Vented Wedge & Gear Operator
Q		Q	BRITISH (ISO 228) PARALLEL THD			000V	Vented Wedge
R		R	SW X REDUCED NPT			000W	Chain Wheel Operated
S	METAL OCTAGONAL RING	S	NPT x REDUCED NPT			000X	Xylan Coated Fasteners
T	316 + TFE	T				00AA	Trim: Inconel 625 Stem with Full Stellite 6 Seats and Wedge
U	304 + TFE	U	SOCKETWELD X F-NPT			00AB	***
V	304L + GRAPHITE	V				00AC	***
W		W	SOCKETWELD (SW)			00AD	***
X	MONEL + TFE	X				00AE	***
Y		Y	F-NPT X BUTTWELD			00AF	***
Z	***	Z	***			00AG	***

6. For spring loaded check valves only, the third digit of the material option code will represent the spring material. The letter "O" may be used for 302 or 316L stainless steel springs. 316L

7. HF = Stellite hardfaced overlay. For seats and wedges/discs where weld deposited facings are used, the base material is equal to the stem material or at least equal in corrosion

8. The grouping may be prefixed by "CE" to indicate compliance with the European Commission Pressure Equipment Directive 2014/68/EU.

9. The grouping may also be suffixed with a MANUFACTURING CODE, for special requests which will be separated from the rest of the valve figure number by a hyphen (-).

# STYLE CODE INDEX

## Gate Valves

Gate Valves			
Valve Style	Pressure Class	Flow Bore	Bonnet/Cover
0800	800	CP	BB
0870	800	CP	WB
0888	800	FP	BB
5870	800	FP	WB
1500	1500	CP	BB
1570	1500	CP	WB
1588	1500	FP	BB
1578	1500	FP	WB
2578	2500	FP	WB
0815	150	CP	BB
0830	300	CP	BB
0860	600	CP	BB
5815	150	FP	BB
5830	300	FP	BB
0895	1500	FP	BB
2595	2500	FP	BB

Cryogenic Gate Valves			
Valve Style	Pressure Class	Flow Bore	Bonnet/Cover
C800	800	CP	BB
C870	800	CP	WB
C815	150	CP	BB
C830	300	CP	BB
C860	600	CP	BB

Bellows Seal Gate Valves				
Valve Style	Pressure Class	Flow Bore	Bonnet/Cover	Notes
B800	800	CP	BB	
B870	800	CP	WB	
B888	800	FP	BB	
B815	150	CP	BB	
B830	300	CP	BB	
B860	600	CP	BB	
B817	150	CP	WB	
B837	300	CP	WB	
B867	600	CP	WB	
B811	800	CP	BB	Male Thread x Female Thread
B812	800	CP	BB	Male Plain x Female Thread
B813	800	CP	BB	Male Thread x Female S/W
B814	800	CP	BB	Male Plain x Female S/w
B867	800	CP	WB	Male Thread x Female Thread
B877	800	CP	WB	Male Plain x Female Thread
B878	800	CP	WB	Male Thread x Female S/W
B879	800	CP	WB	Male Plain x Female S/w
B874	800	CP	BB	Integrally Reinforced Extended Body (IREB)
B875	800	CP	WB	Integrally Reinforced Extended Body (IREB)

Extended Body Gate Valves				
Valve Style	Pressure Class	Flow Bore	Bonnet/Cover	Notes
0811	800	CP	BB	Male Thread x Female Thread
0812	800	CP	BB	Male Plain x Female Thread
0813	800	CP	BB	Male Thread x Female S/W
0814	800	CP	BB	Male Plain x Female S/W
0876	800	CP	WB	Male Thread x Female Thread
0877	800	CP	WB	Male Plain x Female Thread
0878	800	CP	WB	Male Thread x Female S/W
0879	800	CP	WB	Male Plain x Female S/W
0874	800	CP	BB	Integrally Reinforced Extended Body (IREB)
0875	800	CP	WB	Integrally Reinforced Extended Body (IREB)



# Globe Valves

Globe Valves				
Valve Style	Pressure Class	Flow Bore	Bonnet/Cover	Notes
OG80	800	CP	BB	
OG87	800	CP	WB	
NG80	800	CP	BB	NEEDLE GLOBE
NG87	800	CP	WB	NEEDLE GLOBE
G150	1500	CP	BB	
G157	1500	CP	WB	
OG81	150	CP	BB	
OG83	300	CP	BB	
OG86	600	CP	BB	
G895	1500	CP	BB	
G259	2500	CP	BB	
FG80	800	CP	BB	
FG81	150	CP	BB	

Bellows Seal Globe Valves				
Valve Style	Pressure Class	Flow Bore	Bonnet/Cover	Notes
BG80	800	CP	BB	
BG87	800	CP	WB	
BG15	1500	CP	BB	
BG17	1500	CP	WB	
BG81	150	CP	BB	
BG71	150	CP	WB	
BG83	300	CP	BB	
BG73	300	CP	WB	
BG86	600	CP	BB	
BG76	600	CP	WB	
BG89	1500	CP	BB	
BY15	1500	FP	BB	Y-Pattern

Y-Pattern Globe Valves			
Valve Style	Pressure Class	Flow Bore	Bonnet/Cover
YG80	800	FP	BB
YG87	800	CP	WB
YG15	1500	FP	BB
YG17	1500	CP	WB
Y162	1690	FP	Bonnetless
Y262	2690	FP	Bonnetless
Y452	4500	FP	Bonnetless

Cryogenic Globe Valves			
Valve Style	Pressure Class	Flow Bore	Bonnet/Cover
CG80	800	CP	BB
CG87	800	CP	WB
CG81	150	CP	BB
CG83	300	CP	BB
CG86	600	CP	BB

# Check Valves

Piston Check Valves		
Valve Style	Pressure Class	Bonnet/Cover
OC80	800	BC
SC80	800	BC
OC87	800	WC
SC87	800	WC
C150	1500	BC
SC15	1500	BC
C157	1500	WC
SC17	1500	WC
OC81	150	BC
SC81	150	BC
OC83	300	BC
SC83	300	BC
OC86	60	BC
SC86	600	BC
OC89	1500	BC
SC89	1500	BC
SC29	2500	BC

Ball Check Valves		
Valve Style	Pressure Class	Bonnet/Cover
OB80	800	BC
SB80	800	BC
OB87	800	WC
SB87	800	WC
B150	1500	BC
SB15	1500	BC
OB17	1500	WC
SB17	1500	WC
OB81	150	BC
SB81	150	BC
OB83	300	BC
SB83	300	BC
OB86	600	BC
SB86	600	BC
OB89	1500	BC
SB89	1500	BC
SB29	2500	BC

Swing Check Valves		
Valve Style	Pressure Class	Bonnet/Cover
SW80	800	BC
SW81	150	BC
SW83	300	BC
SW86	600	BC

Union Ball Check Valves		
Valve Style	Pressure Class	Bonnet/Cover
UB80	800	Vertical

Y-Pattern Check Valves		
Valve Style	Pressure Class	Bonnet/Cover
YC80	800	BC
YC87	800	WC
YC15	1500	BC
YB80	800	BC
YB87	800	WC
YB15	1500	BC
YC16	1690	TC
YC26	2690	TC

\*All check valves available in conventional port only

# HANDWHEEL COLOR CODING

Unique color coding for gate & globe valves. Handwheel color indicates body-bonnet material or special packing.

<b>BLUE</b> ASTM A105 Carbon Steel
<b>WHITE</b> ASTM 182 F5 5 Cr, 1/2 Mo
<b>PURPLE</b> MONEL
<b>YELLOW</b> ASTM A182 F11 1 1/4, Cr, 1/2 Mo
<b>GREEN</b> ASTM 182 F9 9 Cr, 1 Mo
<b>ORANGE</b> ASTM A350 LF2 Low Temp
<b>PINK</b> F20 (ALLOY 20)
<b>SILVER</b> ASTM A182 F316 ASTM A182 F316L 316 SS
<b>BROWN</b> ASTM A182 F22 2 1/2 Cr, 1 Mo
<b>RED</b> Teflon Packing Gaskets or Seals 500F/250C Max Temp



Stainless steel nameplate color indicates trim material (gate, globe, check)



13 Cr Stainless  
Soft Stem, Wedge &  
Seats per NACE



316 Stainless Steel Trim



Standard 13 Cr Trim,  
Stem, Wedge  
Hard-Faced Seat Rings



Special Trim



Monel Trim





# **SMITH VALVES**

Published technical data and general information are intended solely for the coverage of typical applications for users of Smith Valves products featured in this catalog. Please contact Smith Valves for specific questions, technical assistance, or to produce your own study, data and conclusions related to the quality and performance of our products to a specific application. Smith Valves is not responsible for property damage and/or personal injury that may result from failure to follow these instructions. Any information listed in this brochure is subject to change with regard to time sensitivity, error correction, product and design introduction, modification or discontinuation, as well as any other changes Smith Valves considers appropriate.

713.590.1312 • [www.smithvalves.com](http://www.smithvalves.com) • [sales@smithvalves.com](mailto:sales@smithvalves.com)

© 2021 Smith Valves  
REV\_April