

FORCE

Floating Ball Valves

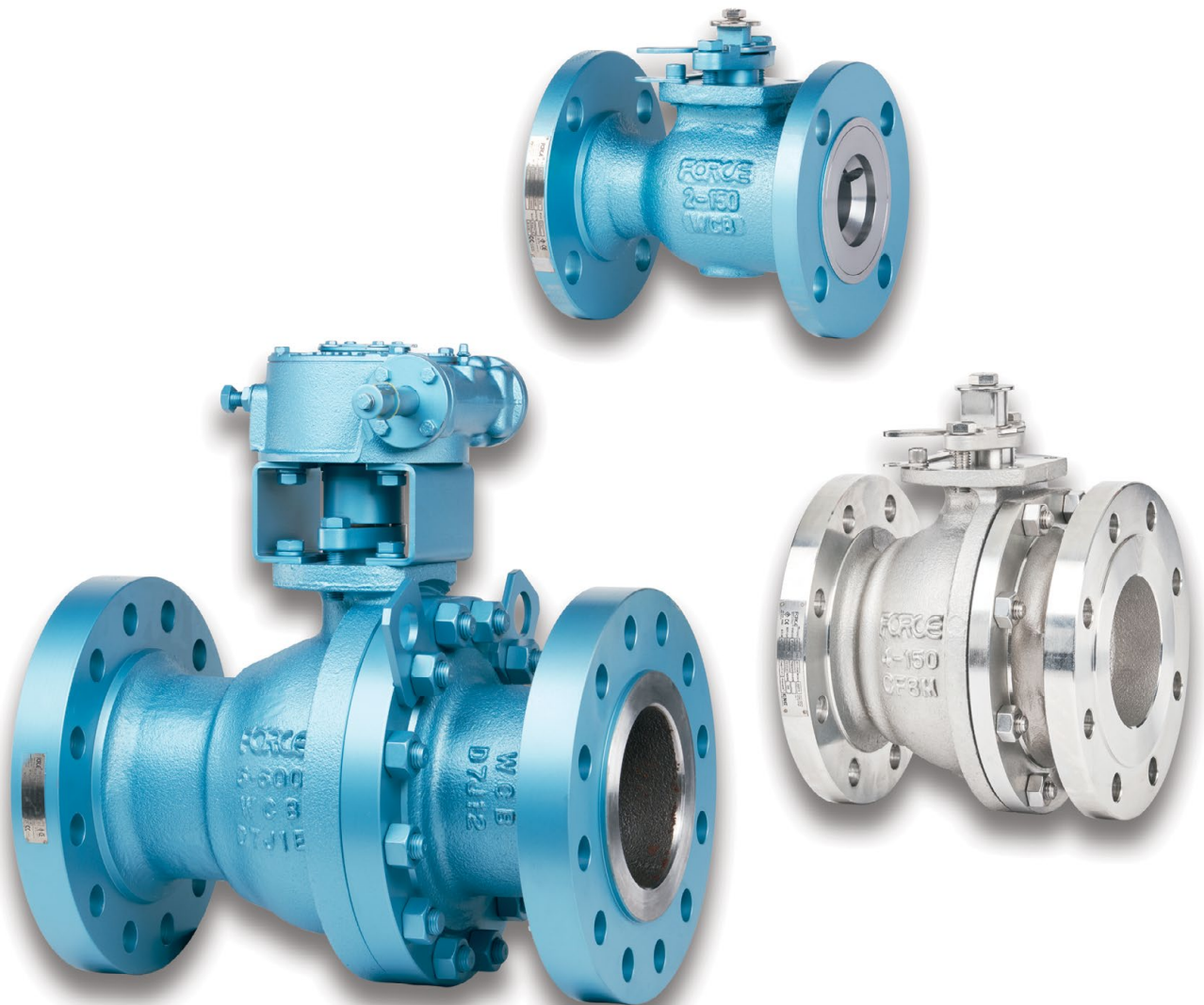



ABOUT CNC FLOW CONTROL

Founded in 2017, CNC Flow Control is new only in name. Headquartered in Houston, this single business entity unifies several trusted valve and flow line brands from across industry, creating an experienced, collaborative and diverse team. From extensive, long range projects to same-day delivery of commodity valves, our team is dedicated to understanding customers' needs in order to ensure exceptional service and the best solutions.

A full service Valve Repair & Modification Shop is on site at the manufacturing facility as well as an in-house engineering team for technical assistance and expertise. Product brands in the CNC Flow Control family include C&C, SMITH, Diamond Gear, Econ and Force.



ABOUT FORCE

FORCE® Valve quality is guaranteed by strictly adhering to ISO 9001 and API Q1 audited quality standards. Dedicated to providing the highest quality valve products to meet customers' expectations, **FORCE**® Valves are manufactured in strict accordance with all applicable ASME, API and other standards.

Every valve is tested and documented to API 6D testing requirements and manufactured to comply with NACE standards with complete MTR traceability.

CONTENTS

DESIGN HIGHLIGHTS	02
FLOATING BALL VALVE FEATURES	03
FIRE SAFETY	04
PARTS LIST AND MATERIAL SPECIFICATIONS	05 - 08
FLOATING BALL VALVES	09 - 10
MATERIALS	11
METAL SEATED BALL VALVES	12
3-WAY 4-SEAT BALL VALVES	12
GEAR ACTUATOR DATA	13
HOW TO ORDER A FORCE® BALL VALVE	14
NOTES	
CONTACT DETAILS	



DESIGN STANDARDS

Item	Standard (latest edition)
Shell Wall Thickness	
Class 150, 300 and 600	ASME B16.34
Pressure Temp Rating	ASME B16.34
Pressure Test	
Class 150, 300 and 600	API 6D
Face to Face Dimensions	ASME B16.10
End Flange Dimensions	ASME B16.5
Mounting Pad Class 600	ISO 5211
Visual Casting Inspection	MSS SP-55
Fire Test	API 607 & API 6FA
General Design	ASME B16.34, API 6D, CSA Z245.15-17, PED 2014/68/EU
Material Requirements	NACE MR0175
Quality Control	API 6D

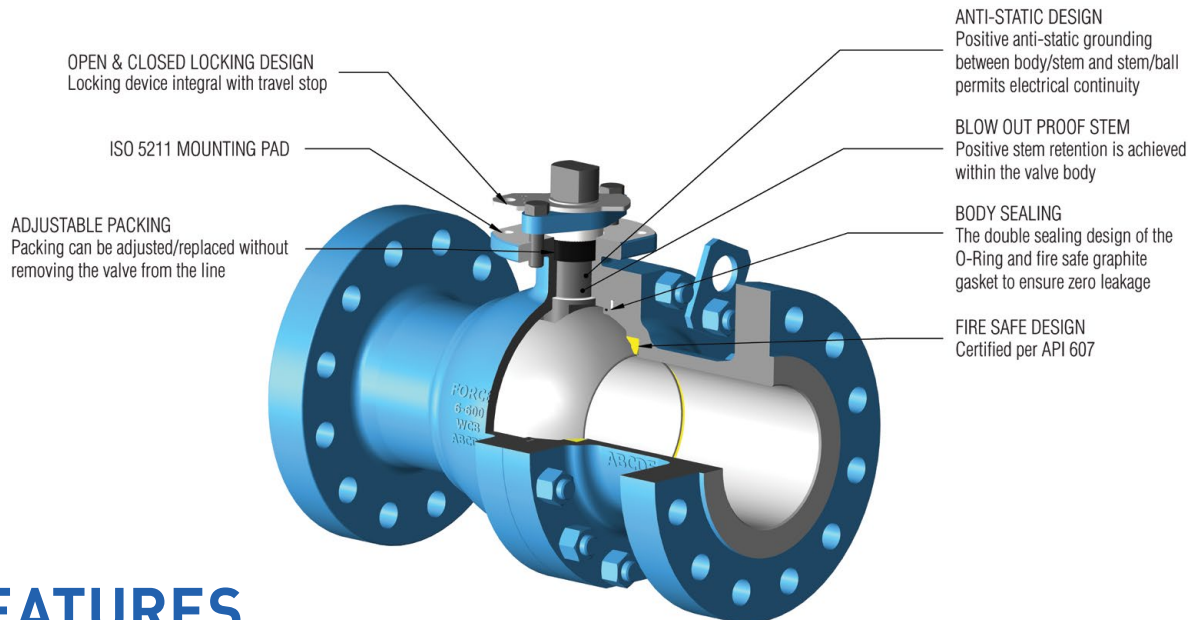

FEATURES

- Full Bore & Reduced Bore
- Metal to Metal Construction
- Floating Ball Design
- Lip Seal or Plate Seal
- Locking Device
- NACE Standard
- Blow-Out Proof Stem
- Fire Safe Design
- Flexible Cavity Relief Seats
- Two Radius of Ball Edge for Long Life Cycle
- Anti-Static Grounding Device
- Double “D” Stem
- ISO Mounting Pad

APPLICABLE SEAT MATERIALS

- TFM1600
- PEEK Seat
- Devlon®
- Other materials can be supplied upon request

FLOATING BALL VALVE FEATURES

General

FORCE floating ball valves are designed in accordance with API 6D for ASME Class ratings 150 to 2500, Nominal sizes from 1/2" to 12". Valves have been designed for use with various combinations of materials such as: Carbon Steel, Low Carbon Steel, Special Alloy, Stainless Steel, Monel, Inconel.

Body Joint Construction

The two piece bolted body designs include a tight toleranced overlapping metal fit between the body and the adapter to minimize any possibility of movement due to pipeline stress. A special high temperature spiral wound stainless steel / grafoil filled gasket is utilized for absolute seal. This gasket is encapsulated by the body and adapted on all four sides. Body and adaptors are dimensioned for metal contact to ensure correct gasket crush.

Blow-Out Proof Stem

Stem is made separately from the ball, blow-out proof design with suitable PTFE and graphite rings and antistatic device. The lower end of the stem is designed with an integral collar to be blowout-proof.

Anti-Static Device

All floating flanged ball valves include dual grounding systems from stem to ball and stem to body. An antistatic feature is provided to ensure electrical continuity. (Fig. 2)

Top Works

Mounting dimensions per ISO-5211.....(Fig. 3)

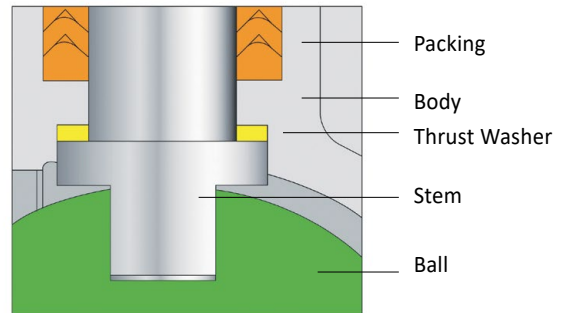

Fig. 1

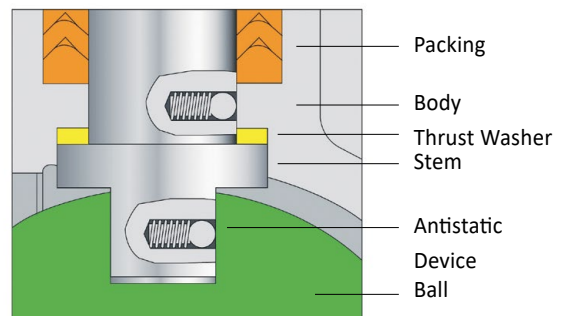

Fig. 2

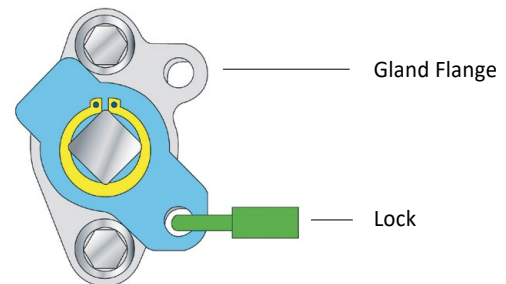

Fig. 3

FIRE SAFETY

All fire-safe valves conform to API 607 and API 6FA standards.

When a fire occurs, soft components such as seats, thrust washers, packing and non-metal gaskets burn out and seals are achieved by metal to metal contact..

FORCE's metal to metal back-up feature will control both interal and external leakage.

Longevity of Life

Special consideration was devoted to the attainment of enhanced life and operation of our valve throughout design, development, testing and manufacturing stages. Valve designs combined with the selection of advanced materials are such that long periods of inactivity should not affect the operations of efficiency.

Contact between stem and valve shell

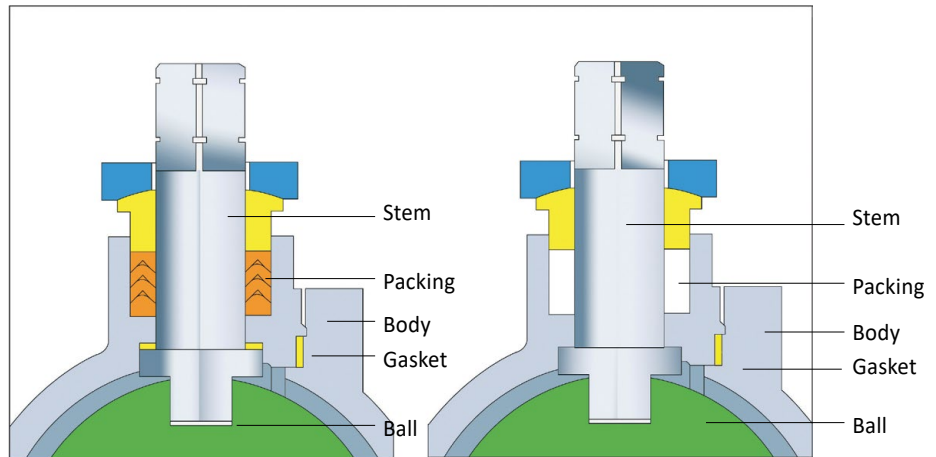

Fig. 5 (Before Fire)

Fig. 6 (After Fire)

Metal-to-metal contact

Contact between ball and valve shell

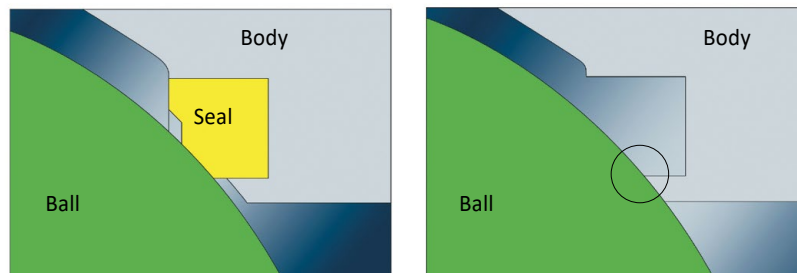
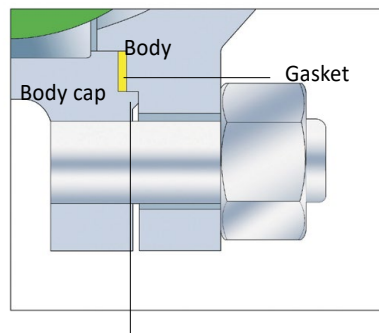

Fig. 7 (Before Fire)

Fig. 8 (After Fire)

Metal-to-metal contact

Valve shell coupling flanges of split body design



Secondary metal to metal conduit

PARTS LIST AND MATERIAL SPECIFICATIONS (TYPICAL)

Model BU

STANDARD MATERIALS OF CONSTRUCTION

ITEM NO.	PART NAME	QTY	CARBON STEEL
1	BODY	1	A216-WCB
2	RETAINER	1	A216-WCB
3	BALL	1	A351-CF8M
4	SEAT	2	TFM 1600
5	STEM	1	A276-316
6	THRUST WASHER	1	PTFE
7	PACKING	1 SET	GRAPHITE
8	GLAND	1	A276-316
9	GLAND FLANGE	1	A351-CF8
10	GLAND BOLT	2	A193-B8
11	O-RING	1	HNBR
12	GASKET	1	SPW316+GRAPHITE
13	STOPPER	1	A240-304
14	SNAP RING	1	A686-W1
15	LOCKING PLATE	1	AISI 1020
16	LOCKING PLATE BOLT	2	A307-B
17	HANDLE	1	A536
18	TOP WASHER	1	A240-304
19	TOP BOLT	1	A193-B8

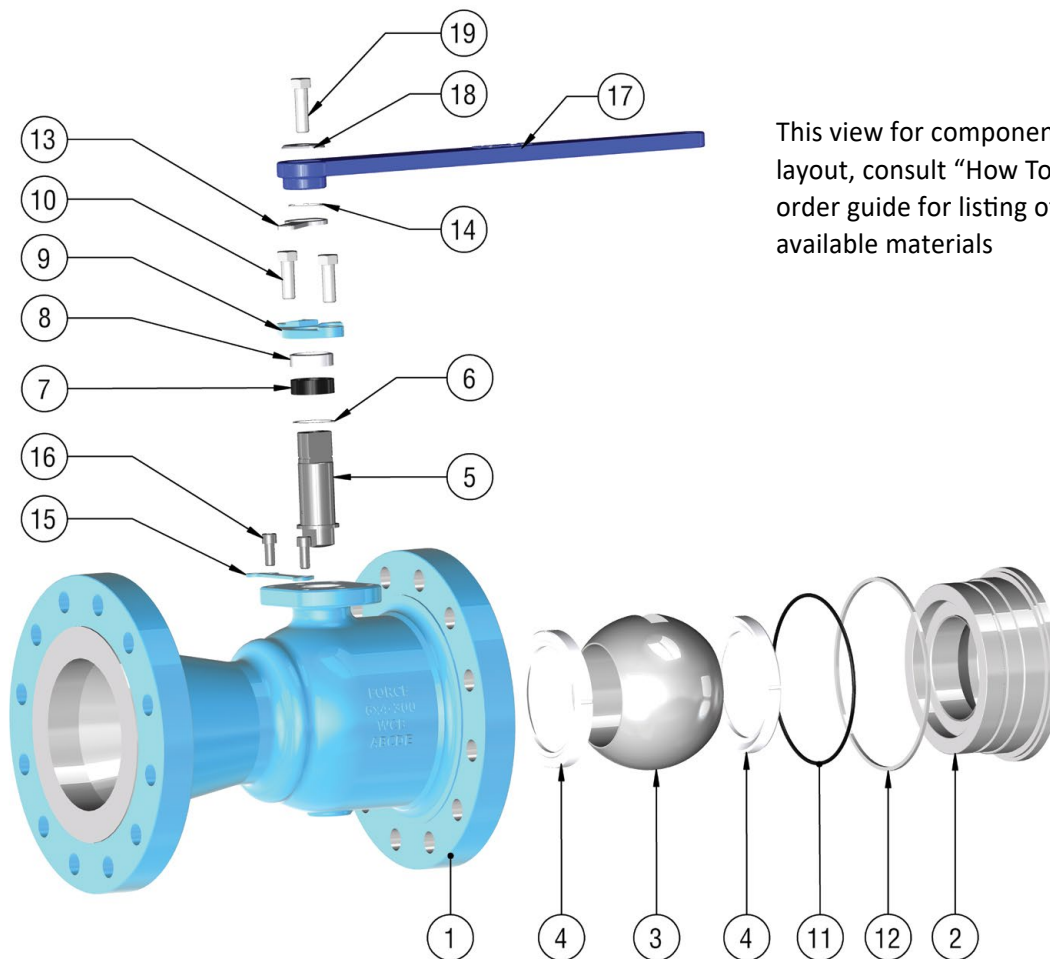

Seat Material P-T Rating

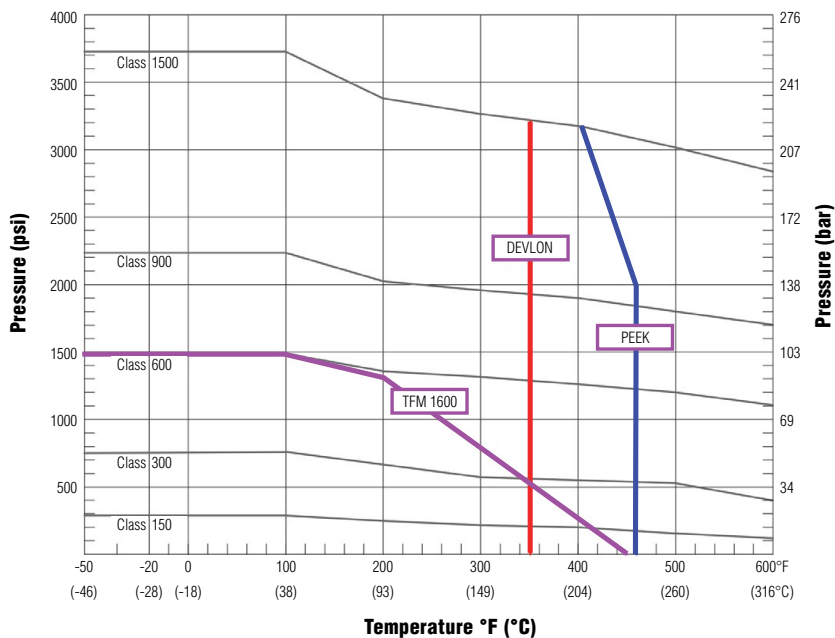

Elastomeric Material Temperature		
Material	Min. (°F/°C)	Max. (°F/°C)
HNBR - 90	-50/-46	350/180
FKM (Viton) -90	-22/-30	356/180

Estimated Torque Data for Model Bu

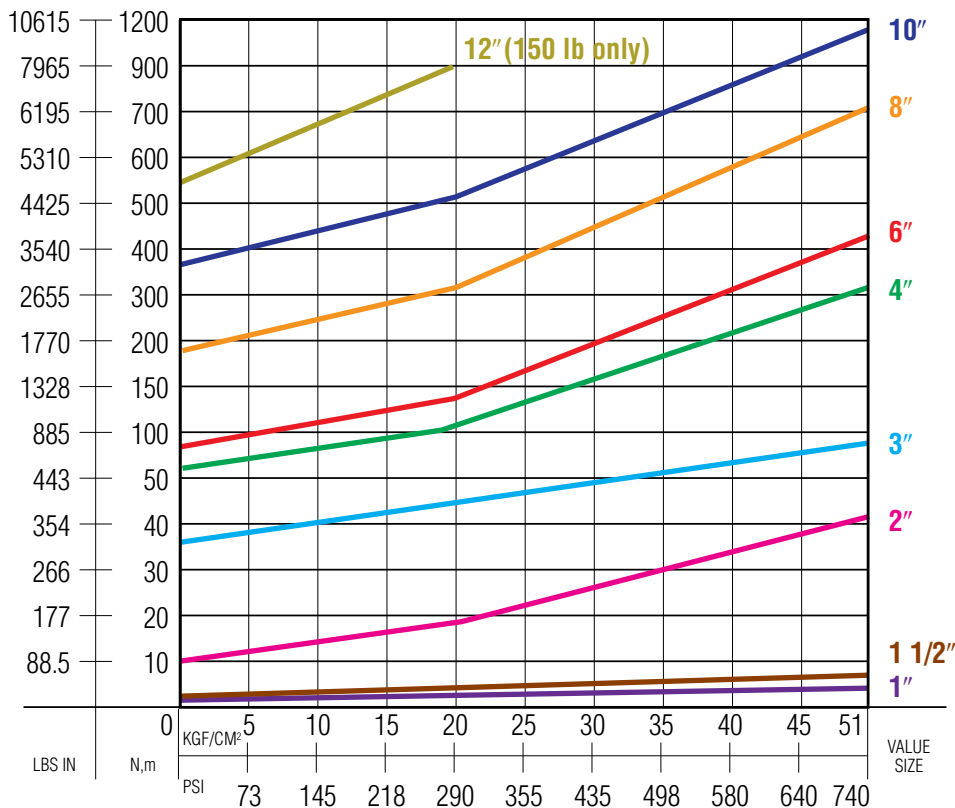

Seat Material:
Reinforced PTFE. When selecting an actuator, add a 25% safety factor to the required torque or contact us directly for exact information.

STANDARD MATERIALS OF CONSTRUCTION

ITEM NO.	PART NAME	QTY	CARBON STEEL
1	BODY	1	A216-WCB
2	END CAP	1	A216-WCB
3	BALL	1	A351-CF8M
4	SEAT	2	DEVLON
5	STEM	1	A276-316
6	THRUST WASHER	1	PTFE
7	GLAND PACKING	1 SET	GRAPHITE
8	GLAND	1	A276-316
9	GLAND FLANGE	1	A351-CF8
10	GLAND BOLT	2	A193-B8
11	O-RING	1	HNBR
12	GASKET	1	SPW316+GRAPHITE
13	END CAP BOLT	1 SET	A193-B7M
14	END CAP NUT	1 SET	A194-2HM
Lever Operated			
15	STOPPER	1	A240-304
16	SNAP RING	1	A581-W1
17	HANDLE GUIDE	1	A216-WCB
18	SET SCREW	2	A193-B8
19	HANDLE	1	CARBON STEEL
Gear Operated			
20	MOUNTING BRACKET	1	AISI 1020 Zn Plated
21	MOUNTING BOLT	1 SET	A193-B8
22	STEM COUPLER	1	A479-410+ENP
23	KEY	1	AISI 1045
24	GEAR BOX	1	A536

This view for component layout, consult how to order guide for listing of available materials. O’ring (11) class 600 and higher only.

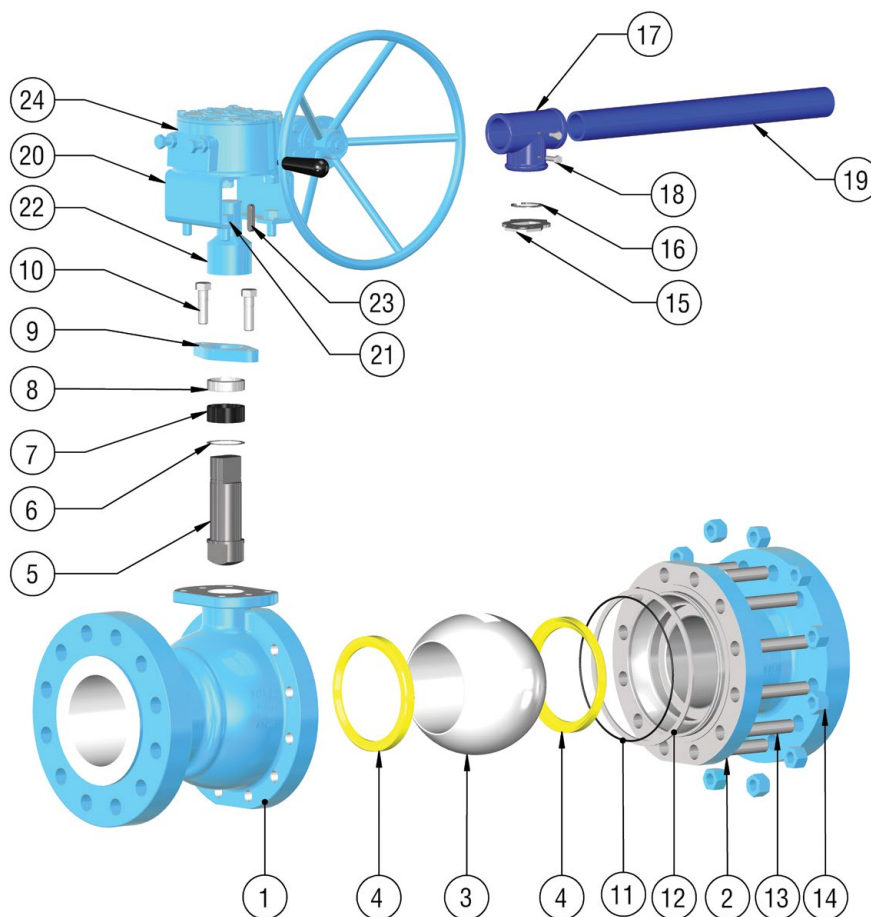

Estimated Torque Data for Model Bf

Class
150, 300, 600

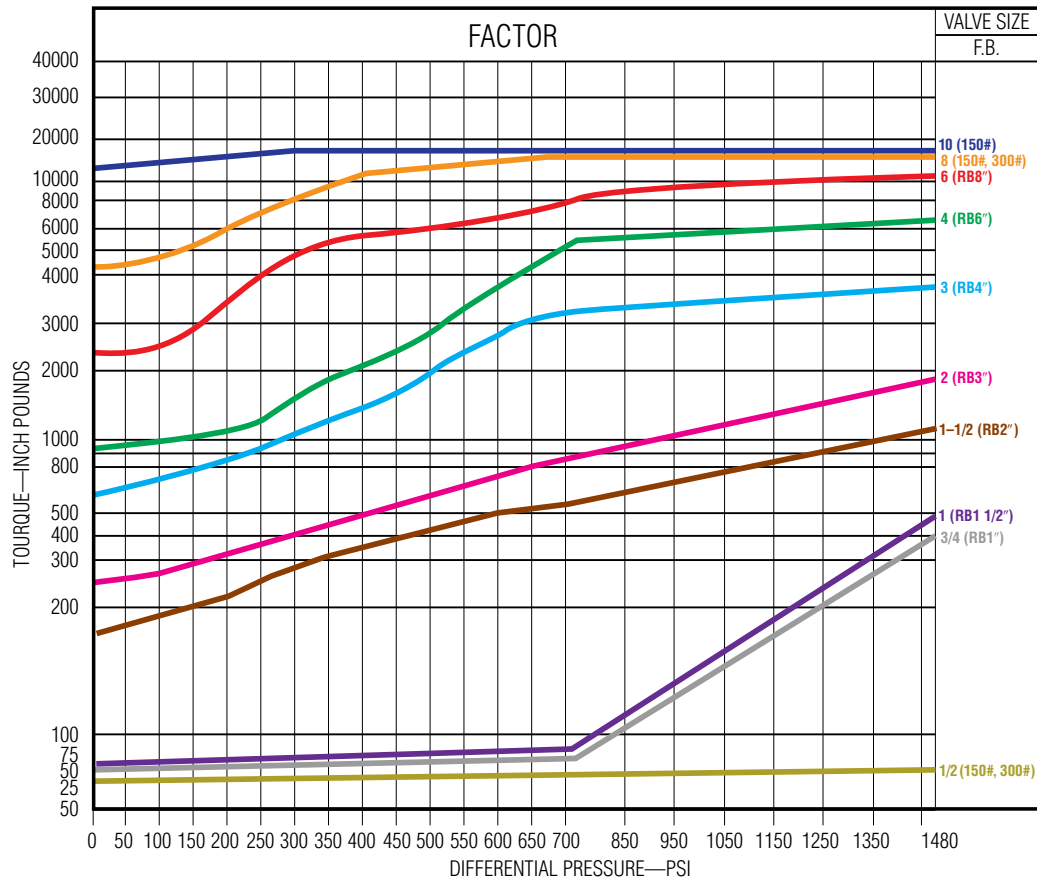

Seat Material: Reinforced PTFE. When selecting an actuator, add a 25% safety factor to the required torque.

For exact torque information, contact us.

FLOATING BALL VALVES

Floating Ball Valves ASME 150 & 300

BU Series

Reduced bore:
sizes 1-1/2" to 12"
For pipeline, oilfield or
process Industry

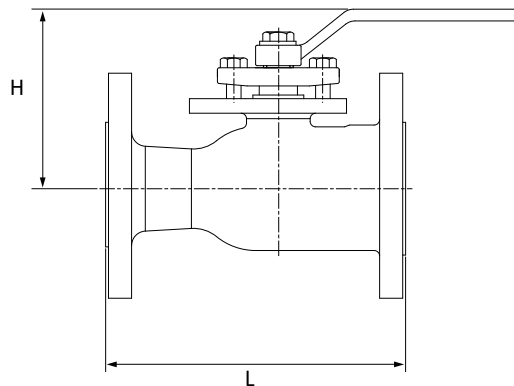

Standard Materials

Body: Carbon Steel (WCB, LCB)
Stainless Steel (CF8, CF8M)
Ball: Stainless Steel (CF8, CF8M)
Stem: SS304, SS316
Seats: PTFE, RTFE, Modified TFE,
TFM1600



CLASS 150 DIMENSIONS Units : inch / mm

NPS	1 1/2	2	2 1/2	3	4	6	8	10	12
BORE	1	1.5	2	2.32	3	4	5.67	7.32	8.66
	25	38	51	59	76	102	144	186	220
L	6.5	7	7.5	8	9	10.5	11.5	13	14
	165	178	191	203	229	266.7	292	330	355.5
H	4	5	5.6	6.1	6.7	8.1	10.9	12.8	16.5
	102	127	142	154	170	206	278	325	419
CV VALUE	106	153	276	317	449	899	1,180	3,277	4,350

CLASS 300 DIMENSIONS Units : inch / mm

NPS	1 1/2	2	3	4	6	8	10
BORE	1	1.5	2.32	3	4.1	5.67	7.4
	25	38	59	76	102	144	203
L	7.5	8.5	11.14	12	15.87	16.5	18
	191	216	283	305	403	419	459
H	4	5	6.1	6.7	8.1	10.9	12.8
	102	127	154	170	206	378	325
CV VALUE	106	156	361	533	1,039	1,402	3,277

Floating Ball Valves ASME 150

BF Series

Full bore: sizes 1/2"
to 12". For pipeline,
oilfield or process
Industry

CLASS 150 DIMENSIONS Units : inch / mm

NPS	1/2	3/4	1	1 1/2	2	2 1/2	3	4	6	8	10	12
BORE	0.5	0.75	1	1.5	2	2.5	3	4	6	8	10	12
	13	19	25	38	51	64	76	102	152	203	254	305
L	4.25	4.61	5	6.5	7	7.5	8	9	15.5	18	21	24
	108	117	127	165	178	191	203	229	394	457	533	610
H	3.3	3.5	4	5	5.6	6	6.7	8.1	13.1	16	18.9	21.3
	84	88	102	127	142	152	170	206	331	406	480	540
CV VALUE	26	61	113	270	470	740	1,250	2,250	5,200	9,550	15,050	23,050

Floating Ball Valves ASME 300

BF Series

Full bore: sizes 1/2" to 12"

For pipeline, oilfield or process Industry

CLASS 300 DIMENSIONS Units : inch / mm

NPS	1/2	3/4	1	1 1/2	2	3	4	6	8	10
BORE	0.5	0.75	1	1.5	2	3	4	6	8	10
	13	19	25	38	51	76	102	152	203	254
L	5.5	6	6.5	7.5	8.5	11.13	12	15.88	19.75	22.38
	140	152	165	191	216	283	305	403	502	568
H	3.3	3.5	4	5.2	5.8	6.8	8.1	13.1	16	18.9
	84	88	102	127	147	173	206	331	406	480
CV VALUE	26	61	113	270	470	1,100	2,150	5,150	9,450	15,050

Standard Materials - (150/300)

Body: Carbon Steel (WCB, LCC)
 Stainless Steel (CF8M)
 Ball: Stainless Steel (CF8M)
 Stem: SS316
 Seats: TFM1600

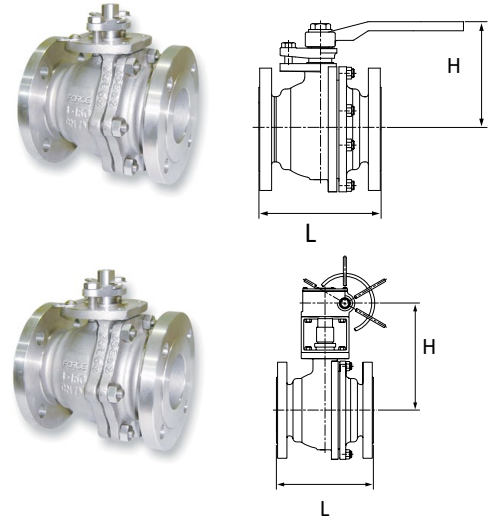

Floating Ball Valves ASME 600

BF Series

Full bore: sizes 1/2" to 6"

Reduced bore: sizes 2" to 8"

For oilfield or process Industry

CLASS 600 DIMENSIONS Units : inch / mm

NPS	1/2	3/4	1	1 1/2	2X 1 1/2	2	3X2	3X3	4X3	4X4	6X4	6X6	8X6
BORE	0.51	0.75	1	1.5	1.5	2	2	3	3	4	4	6	6
	13	19	25	38	38	51	51	76	76	102	102	152	152
L	6.5	7.5	8.5	9.5	11.5	11.5	14	14	17	17	22	22	26
	165	190	210	241	292	292	356	356	432	432	559	559	660
H	3.54	3.66	3.94	4.96	4.96	5.31	5.6	6.7	6.7	8.1	8.1	13.1	13.1
	90	93	100	126	126	135	142	170	170	206	206	331	331
CV VALUE	21	44	75	239	165	450	250	1,050	650	1,900	840	4,650	2,200

Standard Materials - (600)

Body: Carbon Steel (WCB, LCC)
 Stainless Steel (CF8M)
 Ball: Stainless Steel (CF8M)
 Stem: SS304, SS316
 Seats: TFM1600

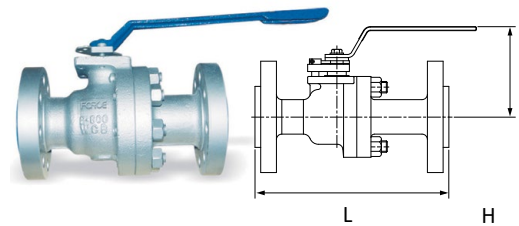

Floating Ball Valves ASME 900 & 1500

BF Series

Full bore: sizes 1/2" to 2"

For oilfield or process Industry

CLASS 900 & 1500 DIMENSIONS Units : inch / mm

NPS	1/2	3/4	1	1 1/2	2
BORE	0.51	0.75	1	1.5	2
	13	19	25	38	51
L	8.5	9	10	12	14.5
	216	229	254	305	368
H	3.9	4	4.5	5.7	6.9
	99	102	115	144	176
CV VALUE	14	34	60	180	380

Standard Materials - (900-1500)

Body: Carbon Steel (WCB, LCC)
 Stainless Steel (CF8M)
 Ball: Stainless Steel (CF8M)
 Stem: SS316
 Seats: Devlon, PEEK

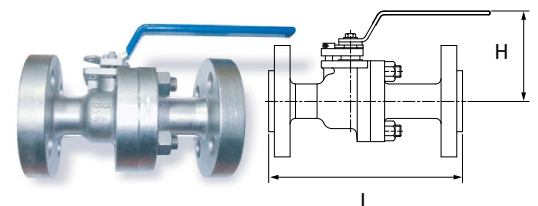

MATERIALS

Body & Trim Material

CARBON STEEL

A 105 A216 WCB A216 WCC

LOW TEMPERATURE CARBON STEEL

A352 LCB A352 LCC A 350 LF2

LOW ALLOY STEEL

AISI 4140 A694 F65 A694 F52
 A694 F60 A350 LF3
 API 6A 60K(A694 F60 Mod)

MARTENSITIC STAINLESS STEEL

A182 F6A A182 F6NM
 A217 CA15 A487 CA6NM

AUSTENITIC STAINLESS STEEL

A182 F316 A182 F316L
 A182 F316LN-Mod. A182 F347
 A182 F44(6% Mo) A182 FXM-19
 (UNS S31254) (Nitronic® 50)
 A351 CF8M A351 CF3
 A351 CF3M

PRECIPITATION HARDENING STAINLESS STEEL

A564 Gr 630 H 1150M (UNS S 17400)

NICKEL ALLOYS

Incoloy® 825 (UNS N08825)
 Inconel® 625 (UNS N06625)
 Inconel 750 (UNS N07750)
 Monel® 400
 Monel K500
 Incoloy 925 (UNS N09925)
 Inconel 718 (UNS N07718)

DUPLEX STAINLESS STEEL

A181 F51 (UNS S31803)
 A182 F53 (UNS S31750)
 A182 F55 (UNS S31760)
 A890-4A (UNS S31803)
 A890-6A (UNS S32760)

MATERIAL FOR SEALING AND SEAT INSERT

MATERIAL	GENERAL TEMPERATURE RANGE	USE / CHARACTERISTICS	NOT RECOMMENDED FOR	PROPERTIES
FM (Viton® A)	-13° F - 400° F (-25° C ~ 204° C)	aliphatic hydrocarbons (petroleum oil, mineral oil/grease, fuel oils, butane, propane, natural gas), aromatic hydrocarbons (benzene, toluene), chlorinated hydrocarbons, high vacuum, most acids/chemicals	brake fluid with glycol base, ammonia gas, amines, alkalis, acetone, skydrol, ethyl acetate, superheated steam, polar solvents (ketone, acetone, acetic acid, etc), low molecular esters and ethers	excellent resistance for wear, ozone, weather, aging, compression set, permeation
FKM (Viton® GLT)	-50° F - 400° F (-45° C ~ 204° C)	extended low temperature service over Viton® A. Excellent for water, steam and mineral acids in addition to use of Viton® A	same as those of Viton® A	similar to those of Viton® A except a little inferior compression set and permeability
HNBR	-50° F ~ +350° F (-46° C ~ +180° C)	dilute acids, weak alkalis, lower alcohols, amines, aliphatic hydrocarbons, kerosene, animal oils and fats, synthetic and mineral oils and lubricants, sweet or sour (H2S) oil & gas, amine corrosion inhibitors, explosive decompression resistant	aromatic phosphate esters, ethers, ketones, aromatic hydrocarbons, chlorine	These materials have the excellent oil/fuel resistance fo traditional nitrile elastomers. Theyalso have superior mechanical properties and can sustain higher service temperatures: e.g. up to 180°C in oil. In addition, they display superior resistance to aggressive fluids such as sour crude oil and have excellent resistance to ozone.
PTFE	-400° F - 450° F (-240° C ~ 232° F)	almost all chemicals and solvents including strong acid and alkali, high and very low temperature service	high mechanical loading	weather resistance, thermal stability, low friction
PEEK (polyether-etherketon)	-40° F - 500° F (-40° C ~ 260° C)	superb chemical resistance including alcohols, acids, ammonia, esters, halogenated organics, hydrocarbons and inorganics	some strong acids - nitric, chromic, sulfuric, benzene sulfonic acids and aqua regia, etc., some inorganics - bromine, chlorine and fluorine, etc.	good high temperature performance, wear resistance, very low smoke and toxic gas emission, good hydrolysis resistance
Polymite	-65° F - 275° F 185° F, water based fluids (-54° C ~ 135° C)	petroleum and water based fluids, phosphate ester fluids, some chlorinated fluids and solvents, ketones, ethylene base glycols	strong acid, alcohols, brake fluids, dry chlorine, water over 185°F	very high sealability, tear strength, abrasion and extrusion resistance

METAL SEATED BALL VALVES

BFM Series

- Full Bore & Reduced Bore
- Applicable Standards
ANSI B16.34, BS5351 & API 6D
- Face to Face: ANSI B16.10
- End Flange Dimensions:
ANSI B16.5

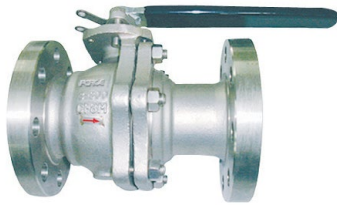

FORCE Metal Seated Ball Valve Features:

- 2-Piece or 3-Piece split body construction
- Manufactured to exact customer specifications / requirements

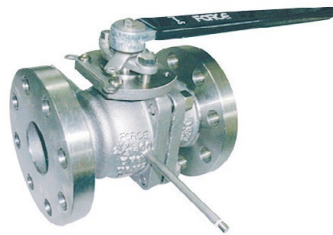

- Provide excellent service in high temperature / high operational frequency applications
- Standard ISO Mounting Pad
- Manufactured to meet ANSI B16.104 Class V and MSS SP-61 sealing requirements
- Standard Fire Safe design



3-WAY 4-SEAT BALL VALVES

- T-Port or L-Port
- Side Entry and Top Entry
- 4-Seat Design
- Face to Face: manufacturer standard
- End Flange Dimensions: ANSI B16.5
- Full Bore

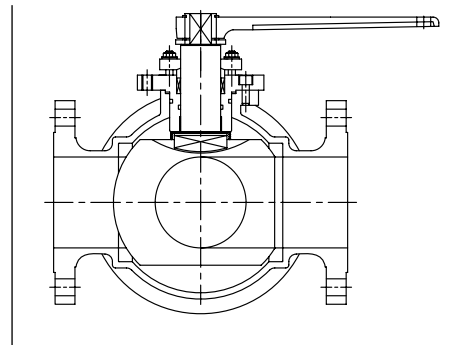

Operating Forms

3-way L-Port

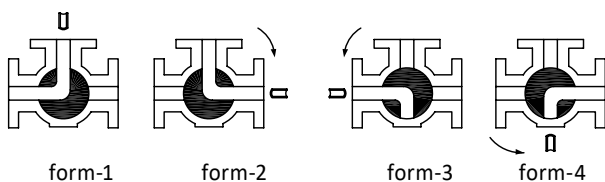

3-way T-Port

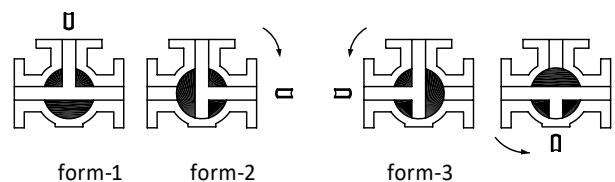

Flow direction is marked on top of stem

GEAR ACTUATOR DATA

Valve Automation

FORCE® is able to offer a comprehensive package of control equipment including actuators, switches, solenoids and positioners. Details of actuator are available on request.

Gear Operated

The gear operator can be furnished upon request

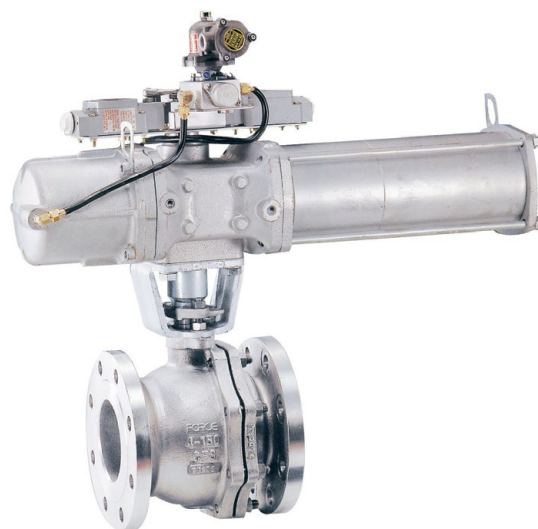
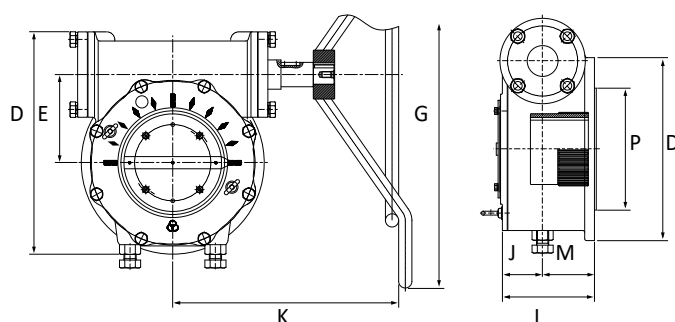

Model No.	Dimension	D	E	G	K	J	M	L	P	Flange Size	Gear Ratio	Max. Torque		Weight	
												inch lb	N-m	lb	kg
DG-W0	inch	6.26	2.32	11.81	5.63	1.54	1.58	3.11	2.76	F10	34:1	11948	1350	13.23	6
	mm	159	59	300	143	39	40	79	70						
DG-W1	inch	7.64	2.72	15.75	6.58	1.81	1.97	3.78	3.94	F14	42:1	19674	2223	24.25	11
	mm	194	69	400	167	46	50	96	100						
DG-W2	inch	8.94	3.27	19.69	10.59	2.17	2.09	4.25	5.12	F16	42:1	24585	2778	41.89	19
	mm	227	83	500	269	55	53	108	130						
DG-W3S	inch	10.59	3.9	23.62	12.72	2.52	2.56	5.08	5.12	F16	43:1	30205	3413	74.96	34
	mm	269	99	600	323	64	65	129	130						
DG-W4S	inch	13.19	5.00	27.56	15.63	3.03	2.87	5.91	7.87	F25	50:1	40976	4630	119.05	54
	mm	335	127	700	397	77	73	150	200						
DG-W4S	inch	13.19	5.00	27.56	15.63	3.03	2.87	5.91	7.87	F25	153:1	111466	12595	158.73	72
	mm	335	127	700	397	77	73	150	200						
DG-W5S	inch	15.75	6.30	31.5	17.72	3.03	3.15	6.18	9.06	F30	50:1	46834	5292	163.14	74
	mm	400	160	800	450	77	80	157	230						
DG-W5S	inch	15.75	6.30	31.5	20.47	3.03	3.15	6.18	9.06	F30	153:1	130042	14694	202.82	92
	mm	400	160	800	520	77	80	157	230						
DG-W6S	inch	19.8	8.00	35.43	21.65	3.62	3.98	7.6	10.24	F35	55:1	57932	6546	302.03	137
	mm	503	203	900	550	92	101	193	260						
DG-W6S	inch	19.8	8.00	35.43	23.62	3.62	3.98	7.6	10.24	F35	213:1	199514	22544	392.42	178
	mm	503	203	900	600	92	101	193	260						

HOW TO ORDER A FORCE® BALL VALVE

Example: A 1", Class 150, 2 Piece, Full Port Floating Ball Valve with Raised Face Flanged End Connections, Carbon Steel Body, Carbon Steel+ ENP Ball and 410 SS + ENP Stem with PTFE Seats, Viton® O-Rings, and Lever is written as 1-BTN11-AAA1L-1.

A	B	C	D	E	F	G	H	I	J
1	BF	1	1	A	A	A	1	L	1

A	Size
0.5	1/2"
0.75	3/4"
1	1"
1.5	1-1/2"
2	2"
3	3"
4	4"
5	5"
6	6"
8	8"
10	10"
12	12"
14	14"
16	16"
18	18"
20	20"
24	24"
30	30"
36	36"

B	Ball Valve Type
BU	1 PC Floating BV
BF	2 PC Floating BV w/ Bolted Body
BN	3-Way BV w/ 90° V-Ball
BV	3-Way BV w/ 120° V-Ball
BT	2 PC Trunnion BV w/o Grease Fitting
BTN	2 PC Trunnion BV w/ Grease Fitting
BUM	1 PC Metal Seated Floating BV
BFM	2 PC Metal Seated Floating BV w/ Bolted Body
BTM	2 PC Metal Seated Trunnion BV w/ Grease Fitting
BUC	Cryo. 1 PC Floating BV
BFC	Cryo. 2 PC Floating BV w/ Bolted Body
BTC	Cryo. 2 PC Trunnion BV w/ Grease Fitting
BP	Pocketless BV
BJ	Jacketed BV

C	Port
1	Full Port
2	Reduced Port

D	Pressure Class
1	Class 150
2	Class 300
3	Class 600
4	Class 900
5	Class 1500
6	Class 2500
7	Other

E	Body Material
A	A216-WCB (A105)
B	A351-CF8 (F304)
C	A351-CF8M (F316)
D	A351-CF3 (F304L)
E	A351-CF3M (F316L)
F	A351-CN7M (Alloy 20)
G	A217-WC1
H	A217-WC6 (F11)
J	A217-WC9 (F22)
K	A352-LCC
L	A352-LC2
M	A352-LC3
N	A352-LCB (LF2)
P	A217-C5
Q	Duplex
R	Monel
S	Hastelloy®
T	Titanium
U	Inconel
V	Super Duplex
X	Other

F	Trim Material
A	WCB+ENP Ball & 410 SS + ENP Stem
B	304 SS
C	316 SS
D	304L SS
E	316L SS
F	Alloy 20
G	410 SS
Q	Duplex
R	Monel
S	Hastelloy®
T	Titanium
U	Inconel
V	Super Duplex
X	Other

G	Seat Material
A	PTFE
B	RTFE (Glass)
C	RTFE (Carbon)
D	TFM 1600
E	PFA
F	PEEK
G	Nylon
H	Metal
I	PCTFE
J	Devlon®
K	Graphite
X	Other

H	End Connection
1	Raised Face Flange (RF)
2	Ring Type Joint Flange (RTJ)
3	Welded End (WE)
4	RF x WE
5	RTJ x WE
6	Socket Weld (SW)
7	SW x Threaded
8	Special

I	Operator
E	Electric Actuator
P	Pneumatic Actuator
G	Gear Operator
B	Bare Stem
L	Lever

J	O-Rings (For BTN Series)
1	Viton®
2	Viton® AED
3	LT HNBR 90
9	Other

BV - Ball Valve

PC - Piece

Cryo. - Cryogenic

BU Series - Standard O-Rings are Viton®

BF Series - Valves do NOT have O-Rings

BTN Series - O-Rings require dash number designation (J)



U.S. - Headquarters

10350 Clay Road, Suite 250
Houston, TX 77041
Toll-Free: 844.398.6449
Fax: 713.466.1715

U.S. - Manufacturing

13750 Hollister Road
Houston, TX 77086
Toll-Free: 844.398.6449
Fax: 713.590.1319

CAN - Distribution Center

Unit 3, 2930 - 51st Ave. NW
Edmonton, AB T6P 0E1
Toll-Free: 866.723.4279
Main: 780.462.9166

CAN - Headquarters

Calgary Place - Bldg 1
850-330 5 Ave SW
Calgary, AB T2P 0L4
Main: 403.930.1930

U.S. Website: www.cncflowcontrol.com

CAN Website: www.cncflowcontrol.ca